

Dear Customer,

Thank you for choosing Randon brand in your new acquisition of trailer/semi-trailer. The company's vocation for innovation is sustained by continuous investments in technology, so that your equipment may feature increasing quality and safety.

We have prepared this manual so you can familiarize yourself with the information that we have compiled for you. It contains important data and instructions on operation and maintenance intended to assist you in gaining maximum performance and satisfaction from its technical features.

We assure you return on the investment you made by purchasing a RANDOM product. Along with your product, you have also purchased the quality and reliability of a brand that is recognized worldwide, in addition to a number of advantages and benefits, such as:

- Wide Authorized Network for road equipment
- Authorized Services
- Genuine spare parts
- Compliance with international quality Standards
- Innovative and advanced technology
- Committed professionals trained by the factory
- Warranty assured by the Factory for your equipment and its spare parts.

For better performance and longer durability of your equipment, RANDOM recommends that you carry out the periodical maintenance procedures provided in this manual. You will also find in this Manual the Certificate of Delivery and Warranty, which is intended to give you instructions on your warranty rights and periods.

If you have any doubts on your equipment, please contact our team and/or our Randon Authorized Network that are available to better assist you.

Randon Staff

TERM OF WARRANTY

RANDON S.A. - Implementos e Participações gives the piece of equipment specified in this certificate a warranty composed of: (three) 3-month Legal Warranty and (nine) 9-month Contractual Warranty, totaling twelve (12) months starting from the date the Client will be billed for the piece of equipment, with no mileage limit, against manufacturing defects only.

By removing the implement, the Customer must check if it is according to the request made and register at the same time with the Distributor, any verified nonconformity, signed the delivery checklist.

For components acquired from third parties, such as accessories, pneumatic valves, cooling equipment, hydraulic kit, and others, Randon transfers to its Customers the same warranty conditions received from its suppliers. Any warranty claim, must be made at a Randon Authorized Network.

Warranty Conditions

The Warranty shall be given provided that the customer has followed the conditions below:

- If the customer followed the instructions given in the Owner's Manual;
- If the equipment was used under regular conditions, without submitting it to overload;
- If the equipment was submitted to the recommended periodical service at the Randon Authorized Net and within the recommended periods;
- Using Randon genuine parts and components in the replacements and maintenance;
- Using lubricants recommended by Randon;
- If repair services and replacements were performed by Randon Authorized Net;
- Upon presentation of the Term of Warranty and/or the Trade Note referring to the acquisition of his equipment.

So that repairs are performed, replacements and/or maintenance, resulting from warranty, within the deadlines mentioned in this Agreement, the implement must be available at the Randon authorized distributor, within thirty (30) days of the effective claim. If not available in this period of thirty (30) days and having passed the warranty period, the Customer will forfeit the repair, replacement and/or maintenance.



Warranty Restrictions

The Warranty does not cover the following items:

- Defects caused by accidents, misuse, reconstruction or modification services performed in the equipment by non-authorized third parties;
- Defects caused by alterations and/or adaptations in components supplied by Randon or by third parties without the prior authorization of Randon, even when performed by a Randon Authorized Representative;
- Normal wear to product and/ or its components, as well as those requiring replacement in periodic maintenance, such as: plastic cover (Bulk canvas, Dry Cargo and Sider), brake linings, brake drums, tires, electrical components, pneumatic repairs, hydraulic repairs, oils, greases and cleaning material and adhesive/ decorative strips;
- Regular maintenance of the equipment such as lubrication, periodic retightening and cleaning of the implement;
- Regular maintenance service such as: alignment of the axles, lubrication, periodical re-tightening and washing of the equipment;
- Bending of the axles and spring packs;
- Personal displacement, expenses with towing, resulting from accidents and misuse of the implement;
- Defects resulting from insufficient lubrication or lack of maintenance;
- Expenses of displacement of implements, fuel and others that may arise as there is the need for service at the Randon Distributors Network;
- Defects resulting from misusing the equipment in operations different from those the equipment has been designed for;
- Immobilization of the equipment and ceasing profits;
- Defects of painting due to the lack of maintenance and/or improper use of cleaning products, see chapter Implement Painting in the Owner's Manual;
- Use of non-genuine Randon parts in the maintenance of the implements.



Note:

- A genuine part, replaced under Warranty at Randon's Authorized Net, has a Term of Warranty equal to that of the equipment;
- A Randon genuine part, purchased at Randon's Authorized Net, has a Term of Warranty against workmanship defects of six (06) months from the date of purchase;
- Randon reserves the right to modify the features and introduce enhancements in its implements, without incurring the obligation to make the same change in the previously manufactured implements;
- The present warranty is part of the purchase contract of the equipment. The contracting parties shall follow all its conditions and terms.

Warranty Period

The Implement referred to in this certificate was tested and the necessary adjustments were made at the factory prior to delivery.

The owner must perform the periodical maintenance services in any Randon Authorized Dealer, as they are crucial for keeping the equipment in good conditions.

For the warranty to be valid and to obtain the best implement performance, it is essential that the maintenance plan recommended in this manual be followed and performed at the Randon Authorized Network.

**Important:**

- Present this manual and certificate in service requests as collateral, which is provided upon removing the acquired implement;
- Keep this Guarantee Agreement with the invoice and Owner's Manual.

**Attention:**

The maintenance tasks and periods foreseen in the item **Maintenance (Periodical Maintenance Chart - initial column, every thirty (30) and ninety (90) days)**, are services indicated by Randon and are extremely important and necessary for the owner to keep his equipment in normal conditions of operation, thus guaranteeing a better performance and greater durability.

**Important:**

During the warranty process, some components such as brake drums, wheels, rims, axle beams, etc. need destructive tests for analysis. In this case, the components will be removed by the Randon Authorized Network and cannot be reused by the customer.

SUSPENSION LUB-FREE

The traditional semi-trailers are fitted with a stamped suspension of 2 or 3 axles, tandem type, with equalizers.

The suspension performs the function of transferring loads between the axles.

The Interlink semi-trailers are fitted with 2-axle stamped suspensions, tandem type, with equalizers, performing the function of transferring loads between the axles.

Randon stamped suspensions are equipped with central support and Lub-Free model equalizers. The main advantages offered by this component are: lubrication-free, longer durability, lower noise and easier maintenance. These advantages are ensured by the "Silent Block" bushing (same concept as torque arms).

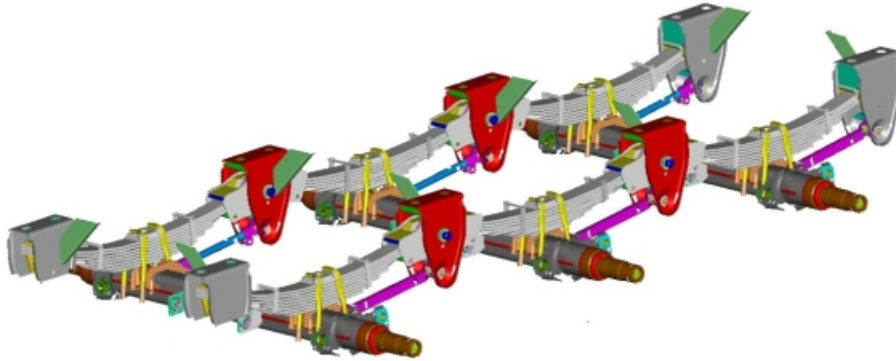

Lub-Free Central Support Features:

1. Stamped support with bushing to secure equalizer;
2. Screw and nut to secure the equalizer to the support;
3. Stamped body equalizer and welded bracket;
4. Silent-block rubber bushing.

Central Support Maintenance:

Visually check the conditions of the items comprising the central support:

- Central support body;
- Equalizer;
- Rubber bushing and screw;
- Pads.



Important:

A torque outside recommendations may cause damages to the central support, screw and rubber bushing. See torque chart in this manual.

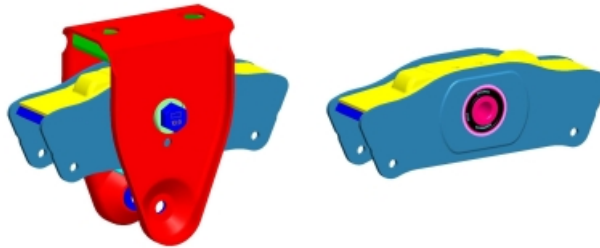

Note:

Whenever the bushings and/or the torque arms are serviced, observe the torque of 70 to 80 kgfm on the torque arm bolt nut.

SINGLE POINT SUSPENSION

As an option, the Single Point suspension 26t. and 32t. can be used in trailers and semi-trailers to operate in severe conditions, such as in the transportation of sugar-cane, forested timber and in the mining area.

The Suspensys Single Point suspension operates with the axles constantly supported on the ground with even load distribution. This is possible thanks to its construction system which features an oscillating central bearing (bracket), semi-elliptical springs fixed to the axle by means of cast iron caps. This system allows a larger working stroke and flexibility of the set and features a larger distance of its components from the ground, making it possible to operate in rough terrain where a lot is required from the suspension in its transversal and longitudinal movements.

The lubrication of the suspension is made only in the central bracket (1), so impurities can be removed, and in the spring housing (2), every 15 days or 5,000 km.

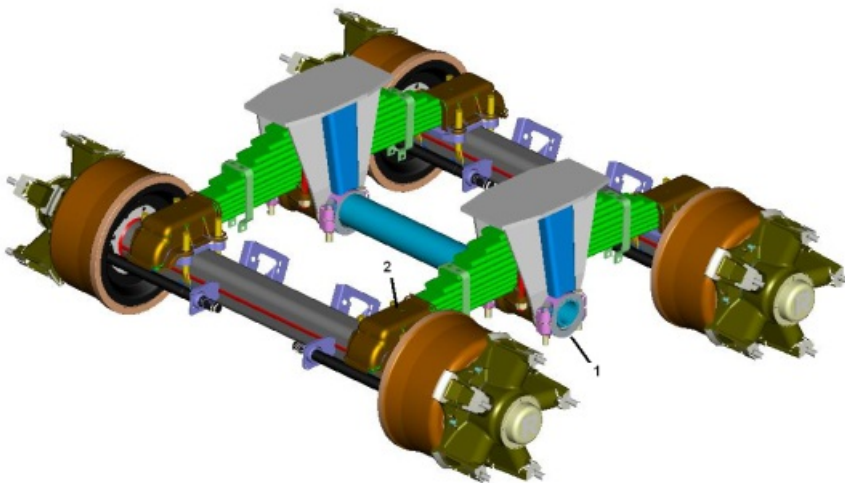

PNEUMATIC SUSPENSION

In order to maintain the stability of the product, the pneumatic suspension is equipped with pneumatic springs and shock-absorbers rather than spring packs. Each axle forms a suspension module, independent from one another, but interconnected by longitudinal pneumatic lines. Its operating principle is based on the continuous maintenance of the distance between the chassis and the ground through the Suspension Leveling Valve. RANDON has two models of pneumatic suspensions:

- **Low Combined Pneumatic Suspension;**
- **PSYS Pneumatic Suspension;**
- **TAS Pneumatic Suspension.**

Low Combined Pneumatic Suspension

This suspension is used on dropped semi-trailers and/or semi-trailers equipped with Self-Steering System. It is fitted with driving springs (metallic) in conjunction with pneumatic springs.

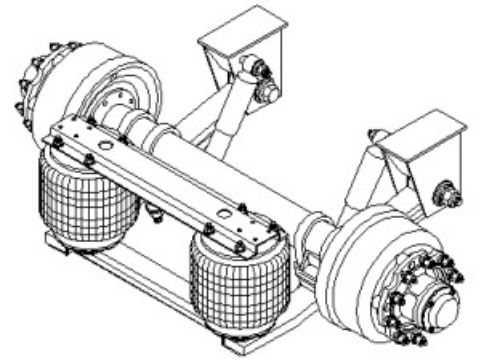

Suspension PSYS

This model of suspension is used on RANDON trailers and semi-trailers where the Combined Pneumatic Suspension is not used.

The axle beam is welded to the arms and the supports are fitted with an adjusting system for axle alignment.

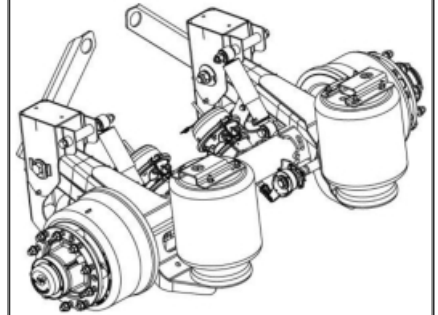

Suspension TAS

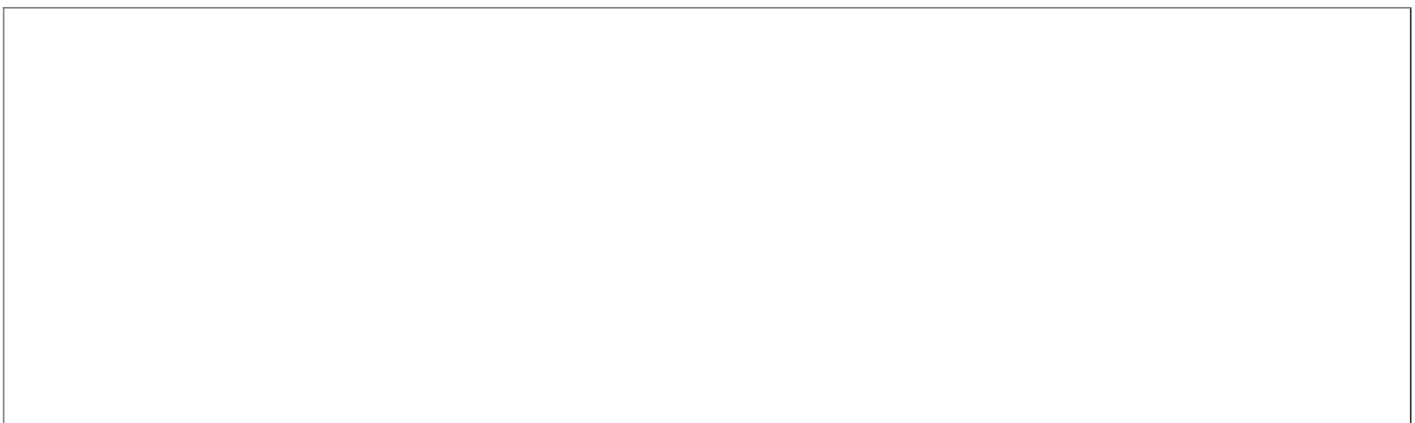

The TAS suspension is a Top Mount pneumatic suspension designed for the different applications found on the market, being ON ROAD or OFF ROAD.

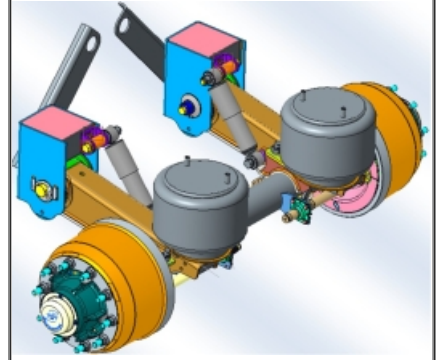

Washer Washer Rating

Follow monthly the level of wear of the polymer washers located between the suspension arm and the support (applied 2 washers on each arm) that has the function of avoiding friction between support and arm.

Position of wear washers	Washer 50% use (half life)	Washer 100% of use (required replacement)

Below is a table comparing the basic features of the pneumatic suspensions used in RANDON products:

	Model of Pneumatic Suspension		
	Low Model	PSYS	TAS
Model of Pneumatic Suspension	212100261	212100261	100000176552
Axle position	Above the driving spring	At the center of the arm	Next pneumatic spring
Adjustment of the Leveling Valve *	X = 250/290 mm	X = 400 mm	X = 400mm

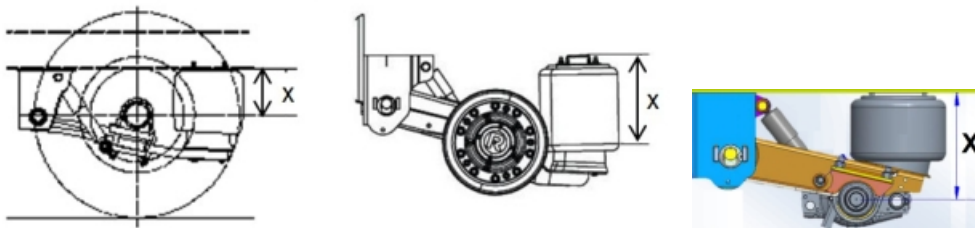

Important:

If the adjustment of the suspension leveling valve is not according to the measurement indicated in the table below, the performance of the suspension will be affected, reducing the useful life of the suspension components and voiding the product warranty. In case your equipment shows the “X” height different from that informed in the above table, please contact the RANDON Authorized Service Outlet nearest you to check/ correct the adjustment of the suspension leveling valve.

Suspension Leveling Valve

It controls the pneumatic suspension operating height, adjusting the pressure of the suspension pneumatic springs and keeping the distance between the chassis and the axle always constant, irrespectively of the load conditions and of the vehicle movement, even in curves.



Platform Leveling Valve

The Platform Leveling Valve is an optional item and is applied only in semi-trailers where all axles are fitted with pneumatic suspensions. It is used to level the semi-trailer base with loading and unloading platforms such as port piers. When the loading and unloading operations are concluded, that is, after deactivating the valve, the pneumatic suspension will level at the height set by the operating leveling valve of the suspension. For instructions on how to operate this valve, please follow the instructions contained in the valve itself.

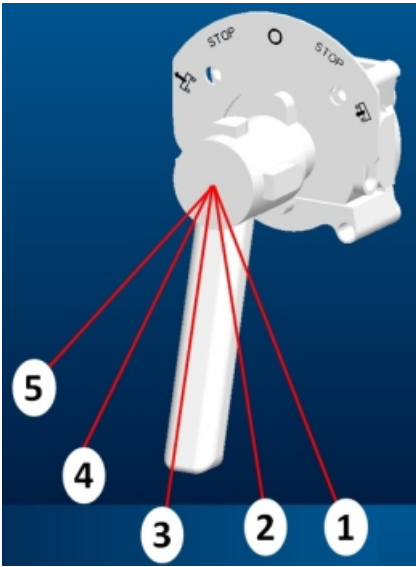

1. Rise;
2. Stop;
3. Traffic (back to normal working height);
4. Stop;
5. Download.

TRAVELLING WITH THE SUSPENSION WITHOUT PRESSURE

When a pneumatic spring blows or the pneumatic circuit shows important leakage, the system will lose pressure, causing the suspension to operate only on the internal bumpers of the pneumatic springs. The equipment will lower approximately 100 mm. If this happens, please repair the damage, pressurize the system again and wait till the suspension levels. The suspension will level itself automatically at the height established at the last adjustment, if this last adjustment has not been changed. The blowing of the pneumatic spring does not disable the equipment from traveling a short distance, in the following conditions:

- If the equipment is fitted with three axles, isolate the affected suspension and pressurize the other suspensions, or run on bumpers (see note below)
- If the equipment is fitted with one or two axles, it will be able to run on bumpers (see note below)



Note:

RANDON recommends to follow the procedures above only when extremely necessary and for a short distance, until you find help, as the whole system and/or the other suspensions will suffer overload, compromising its functioning. We also emphasize that the equipment, in this condition, will not be in its ideal operating conditions, reducing partially its riding control;

Maintenance Instructions

Inspections

- Inspect the components of the pneumatic suspension at regular intervals during its normal operation and whenever the product is repaired;

- Before each trip, visually inspect the suspension system and see if there are no noises and air loss;
- Carry out the following inspection after the first 1600 km of operation. Inspect all screws and nuts, making sure there are no loose screws and nuts and/or excessive movements.
- Check all screw torque values, tightening those which are loose and replacing those which are missing or damaged;
- Check if there are no cracks on the support welding, reinforcements, driving springs, arms, axles, spring shoes (Combined Pneumatic Suspension);
- Check the condition of the pneumatic springs and make sure there are no cuts or signs that they are rubbing against something. When they show damages or cuts, replace them;
- Check shock-absorbers for signs of wear.
- Check shock-absorbers and make sure there are no signs of oil leakage. Should they are damaged or leaking, replace them.



Note:

Check the Periodical Maintenance Table contained in this Manual.

Adjustment of the Pneumatic Suspension Working Height

The adjustment of the Suspension Leveling Valve can be carried out with the equipment loaded or unloaded.

The trailers and semi-trailers equipped with pneumatic suspension leave the factory with the Suspension Leveling Valve adjusted in its break-even point.



Note:

When the equipment is loaded, the suspension must work always leveled, that is, the chassis lower base must be parallel to the ground.



Important:

For maintenance adjustments or further information on the Pneumatic Suspension equipping your RANDON trailer or semi-trailer, consult the RANDON's Authorized Service Outlet nearest you.

AXLES

Conventional Axle

- Tubular beam with load capacity;
- Tapered roller hangers (bearings) mounted on rectified seats;
- disc hubs and axially are made nodular iron;
- Fitted with OUTBOARD brake drum.



Note:

Fitted with OUTBOARD brake drum, which does not require the disassembling of the bracket during the replacement of the brake linings.



Attention:

At every 40,000 km, during brake lining replacements or every time the wheel hubs are disassembled, change the bracket grease and replace the locking washers and the seals, adjusting the bracket slack.

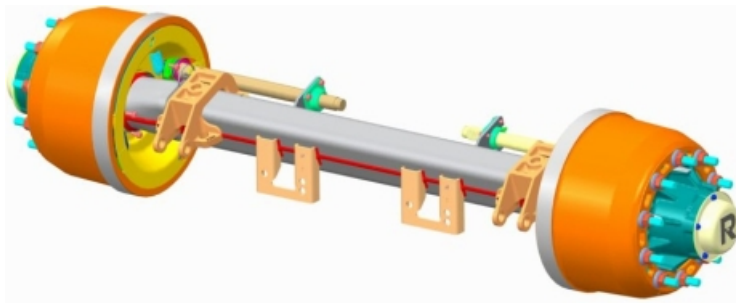

SELF-STEERING SYSTEM

RANDON semi-trailers equipped with spaced axle may have a self-steering component called Self-Steering System. The Self-Steering System is comprised of mechanical and pneumatic components, especially developed by RANDON to equip the semi-trailer with a spaced axle (steering automatic system) that provides better maneuverability and higher stability to the equipment, with less drag of the tires.

The Self-Steering System comprises:

- A turntable to move the system;
- Pneumatic springs to center the system and axle;
- Shock-absorbers to keep the stability and eliminate vibrations from the system.

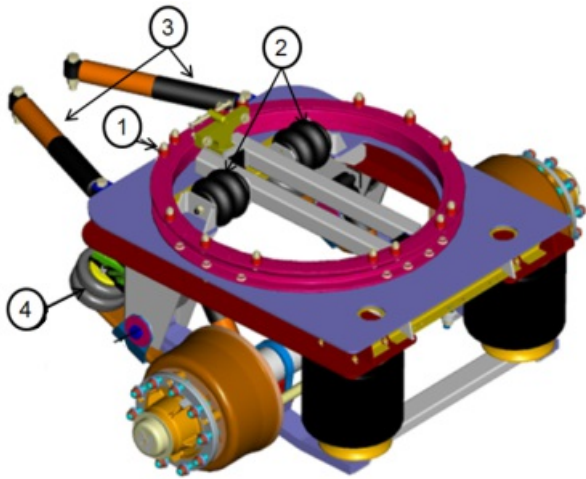

The semi-trailer equipped with the Self-Steering System requires special attention in terms of operation and maintenance. Please check the following sections:

- Pneumatic suspension (ind. 3);
- Turntable, (Articulation Systems) (ind.2);
- Load Adjusting Valve (Independent Pneumatic Suspension);
- Air Axle Lift (ind.1);

Please also check periodically:

- The springs of the centering system, making sure they do not show signs of leakage;
- The shock-absorbers, making sure they do not show damages in the eye and body, loss of efficiency and leakage.
- Alignment of the axle and of the self-steering system.

Inspections







RANDON recommends that you check the following points:

- Make sure the load distribution is correct;
- Check periodically if the shock-absorbers and pneumatic springs do not show leakage or damages;
- Check periodically if the Load Adjusting Valve is functioning well;
- Carry out the inspections indicated in this Manual for the Pneumatic Suspension

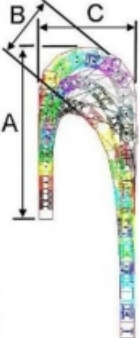
Turning Radius

The turning radius indicates the distance needed to make maneuvers and thus avoid excessive tire dragging and overstressing, which can shorten the lifespan of your tires, torque arms, bearings, equalizers, supports and chassis.

See drawing with the smallest turning radius for Randon trailers/semi-trailers, without running the risk of tire dragging.

MODELOS DE CVC	Articulações	Raio Giro	A (m)	B (m)	C (m)
	1		26,6	8,4	19,4
	1		26,6	8,8	19,4
	1		26,6	9,3	19,4
	2		27,4	8,8	19,0
	3		34,1	13,3	19,4
	2		34,3	13,6	19,2



Comment:

The main function of the self-steering system is to reduce the dragging of the tires. We remind you that the movement of the self-steering axle is limited to 15° to each side, maximum.



Note:

During maneuvers at low speeds, the steering axle shall always be suspended in order to avoid premature wear or damages to the tires.

The self-steering system is equipped with a solenoid valve, connected to the reverse gear light, that will automatically activate the axle lift. This will happen whenever the tractor-truck is operated in reverse gear.



Important:

For the correct operation of the self-steering system with activation through the reverse gear light, please note the following:

- The electric plug for connection to the semi-trailer shall have a 7 pole plug;
- Whenever the semi-trailer is coupled to the tractor-truck, check:
 - If the lights (especially the reverse gear light) are functioning well. In case they are not, test the electric system of both, the tractor-truck and the semi-trailer;
 - If the axle lift is functioning well when the vehicle is operated in reverse gear.



Attention:

Before moving the set (vehicle + semi-trailer) in reverse, make sure that the axle is suspended. This will prevent the self-steering system from turning, which can cause damages to the self-steering system, suspension, tires and chassis.

INDEPENDENT PNEUMATIC SUSPENSION

The RANDON semi-trailers equipped with pneumatic suspension may present the following suspension configurations:

- **3 Axles (1st Pneumatic Axle + 2 Mechanical Axles):** 1st axle with pneumatic suspension and the 2nd and 3rd axles with mechanical suspension.
- **1+2 Axles (1st Spaced Pneumatic Axle + 2 Mechanical Axles):** 1st axle with pneumatic suspension spaced in relation to the 2nd and 3rd axles, which are equipped with mechanical suspension.
- **1+2 Axles (1st Spaced Pneumatic Axle + 2 Pneumatic Axles):** 1st axle with pneumatic suspension spaced in relation to the 2nd and 3rd axles, which are equipped with pneumatic suspension.
- **1+1+1 Axles (1st Spaced Pneumatic Axle + 2 Spaced Pneumatic or Mechanical Axles):** 3 spaced axles, the first one with pneumatic suspension and the 2nd and 3rd ones with either pneumatic suspension or mechanical suspension.

In these configurations, we consider the 1st axle suspension as an Independent Pneumatic Suspension, as in these cases the adjustment of height and load on this axle is controlled by the Load Adjusting Valve.

Load Adjusting Valve

The adjustment of load on the pneumatic suspension is performed through the Load Adjusting Valve (ind. 2). The Load Adjusting Valve is located on the chassis left side and has the function of adjusting the pressure of the suspension pneumatic springs according to the load to be transported.

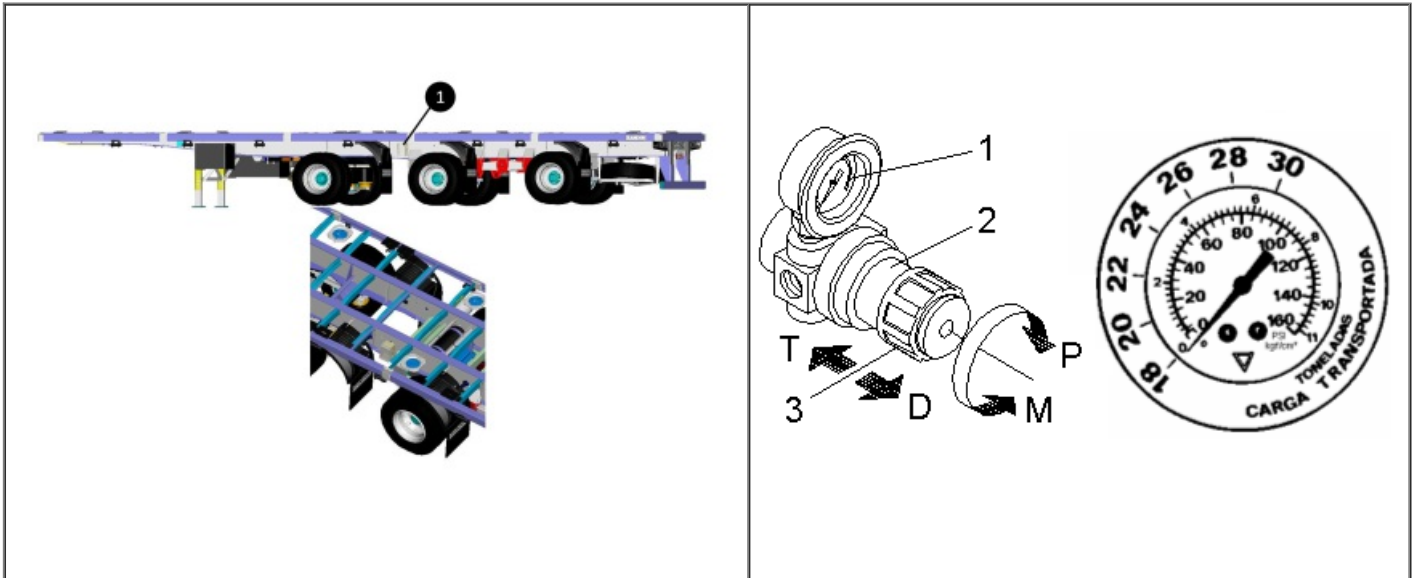

Load Reading: Load reading is made through the table located next to the manometer (ind. 1), which informs the approximate ratio between pressure and transported useful load.



Note:

When traveling, check often if the pressure of the suspension pneumatic springs does not change. The pressure in the manometer (ind. 1) must be the same as the pressure adjusted before loading. If the pressure is different, make a new adjustment.

**Comment:**

These pressures are calculated theoreticians and for a distributed load, in the normal conditions of project. Variations of pressure will be able to happen in the normal conditions of works in function of the type of mechanical horse, type of load and the load distribution.

Pressure Table - Autodirectional Axle

	Tractor Vheicle 4x2 - Traction Semi-Trailer 01+02	Tractor Vheicle 4x2 - Traction Semi-Trailer 01+01+01	Tractor Vheicle 6x2 (6x4) - Traction Semi-Trailer 01+02	Tractor Vheicle 6x2 (6x4) - Traction Semi-Trailer 01+01+01
Liquid Load	Pressure (in bar)			
17.000 kg	3,0	3,2		
18.000 kg	3,2	3,4		3,1
19.000 kg	3,4	3,5		3,2
20.000 kg	3,6	3,6	3,0	3,3
21.000 kg	3,7	3,7	3,2	3,4
22.000 kg	3,9	3,8	3,3	3,5
23.000 kg	4,1	4,0	3,5	3,6
24.000 kg	4,2	4,1	3,6	3,7
25.000 kg	4,4	4,2	3,8	3,8
26.000 kg	4,6	4,3	3,9	3,9
27.000 kg	4,8	4,4	4,1	4,0
28.000 kg	4,9	4,6	4,2	4,1
29.000 kg	5,1	4,7	4,3	4,2
30.000 kg	5,3	4,8	4,5	4,3
31.000 kg	5,4	4,9	4,6	4,4

32.000 kg		5,1	4,8	4,5
33.000 kg		5,2	4,9	4,6
34.000 kg		5,3	5,1	4,7
35.000 kg			5,2	4,8
36.000 kg			5,4	4,9
37.000 kg				5,1
38.000 kg				5,2
39.000 kg				5,3

Adjustment of the Load Adjusting Valve

To begin operation, the circuit air pressure of the semi-trailer must be pressurized with a minimum of 6 bar (6 kgf/cm² or 85 PSI).



Note:

To check, please see manometer located on the truck-tractor. The proper indication of the vehicle's pressure must be regulated with a minimum of 6.5 bar.

Adjustment Instructions:

- To unlock the valve, pull crank (ind. 3) towards "D".
- To increase pressure, turn the crank (ind. 3) clockwise (ind. P);
- To decrease pressure, turn the crank (ind. 3) anticlockwise (ind. M);
- To lock the valve, push crank (ind. 3) towards "T";



Note:

The higher is the pressure indicated in the manometer, the higher is the load on the axle; the lower is the pressure indicated, the lower is the load on the axle.



Important:

For further information about the regulation of the load control valve that equips your Randon semi-trailer, in terms of operation and maintenance, go to RANON Distribution Network.

BRAKE SET

Brake Master "S" Cam, "Q-Plus" series with tubeless system, actuated by compressed air. The shoes are mounted on independent anchoring pins and operated by the camshaft.

They feature semi-circular open at the anchoring pins which allow "fast replacement".

The "Q-Plus" Series have a diameter of 16 " x 8", with tapered linings.

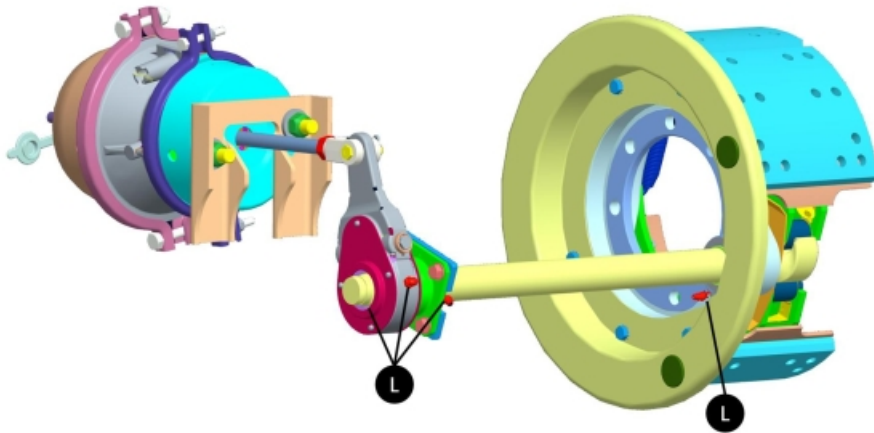

Note:

Check periodically all brake components, especially those which are subject to friction and regular wear, such as: brake linings, springs, drums, seals, etc., always replacing them by RANDON genuine parts when recommended by RANDON or whenever necessary.

It is recommended the use of brake drums up to a maximum of 3 mm above the original diameter.

Original diameter = 419,20 mm

Maximum diameter = 422,20 mm



Important:

The disc axles (with disc hub) allow less ventilation on the wheels, causing the performance - more or less heating of the wheels

- To depend exclusively on the way the driver uses the brakes of the tractor truck and semi-trailer set. Incorrect utilization may lead to overheating and resulting serious damage of components such as the hubs, drums, hangers (bearings), brake components and even the tires.

LUBRICATION OF THE BRAKES

To severe application, the lubrication must be performed at every 15 days, and 30 days to normal application, like the suggested picture below.

ADJUSTMENT OF THE BRAKES

RANDON recommends adjusting the brakes every 2,000 km

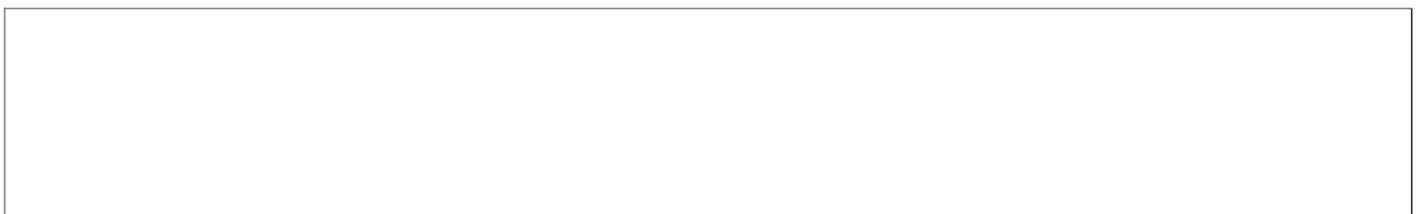

**Note:**

Manual Slack Adjuster Turn the regulating bolt until the linings touch the brake drum return the regulating bolt (1/4 turn).

For a perfect adjustment and efficiency of the brake, carry out the adjustment with the axle raised and with brakes cold.

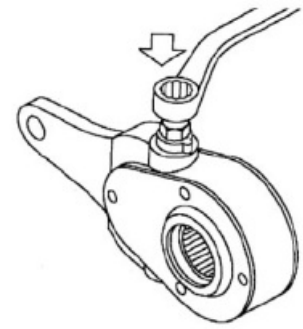

Replacement of the Brake Linings

Brake linings must be replaced when they reach approximately 7mm of thickness ("X"), since from this point on the rivets will rub on the brake drum, damaging its inner surface and jeopardizing the whole set. This may cause total loss of the brake capacity.

For the effective functioning of the brake system, RANDON recommends:

- checking periodically the wear of the brake linings by examining the dustshield plugs (ind.1);
- replacing all brake shoes springs on a mandatory basis (ind. 2 and 3) at every replacement of the brake linings;
- using only genuine brake linings, rivets and springs.

**Note:**

Wear on the brake linings is associated to several factors such as:

- **Characteristics of the area where the equipment is operating;**
- **Weight of the load being transported;**
- **Manner in which the equipment is used by the operator.**

Therefore, it is impossible to determine the mileage limit within which the brake lining will last. Therefore, premature wear of the brake linings is not covered by the warranty.

**Important:**

- RANDON recommends replacing the brake linings at your Authorized Net, thus assuring the use of genuine components and tools and the correct procedure;
- Even though the brake linings, rivets and springs are not covered by the warranty of the equipment, RANDON does not hold any responsibility on the non-observance of the above recommendations, as well as on the consequences thereof.

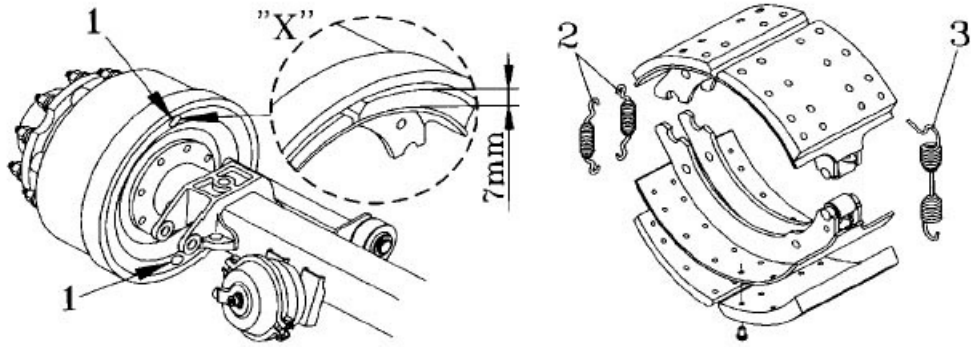

Attention:

Randon warns that the use of brake handle during breaking, overload the brake system because only trailer brake is applied reducing the life and/or damaging components as: brake, coupling and suspension.

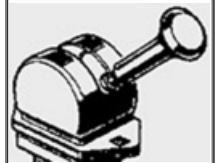

BRAKE AIR SYSTEM

The brake air system of RANDON equipment is in conformity with the traffic legislation in force and it is approved and tested in its original configuration, reaching the efficiency required by Resolution 777/93, of CONTRAN.



Important:

In order to maintain performance the closest possible to its original condition, RANDON recommends using RANDON original parts and components during replacements.



Attention:

The utilization of parts and components of brands and specifications different from the original ones or any alteration in the pneumatic system holds RANDON free from any responsibility.

The brake air system consists of two air lines which interconnect the tractor-truck to the equipment with the purpose of actuating the brakes of the semi-trailers.

These two lines are:

Service Line: it is actuated by means of the brake pedal or by a hand brake, releasing air from the reservoir to the brake chambers and thus applying the semi-trailer or the set;

Emergency Line: it continuously keeps the air reservoir loaded.



Comment:

A pressure difference between the tractor-truck and the semitrailer should not exceed 0,4 bar for the semi-trailer. A different regulation will affect the performance of the set brake system. In case you find a different number when checking, please visit your tractor-truck dealer in order to regulate correctly the control valve that distributes air to the brakes of the tractor-truck and semi-trailer.



Note:

- The pneumatic system of the semi-trailer features a double-retaining valve (ind.14) which avoids double actuation of the brake, that is, of the service chamber and of the emergency chamber together;
- The pneumatic system of the semi-trailer features a pressure valve (ind.10) that checks pressure.



Attention:

The valves for releasing the semi-trailer (ind.7), parking it (ind.8) and of the air axle lift (ind.9) are located inside a specific box located at the equipment left side.

Instructions to Use the Air System

The brake air system of RANDON semi-trailers feature valves and equipment that must be used correctly for better performance and safety to the equipment.



Note:

In the Interlink Semi-trailer, all operating instructions shall be followed in both the front and back-up semi-trailers.

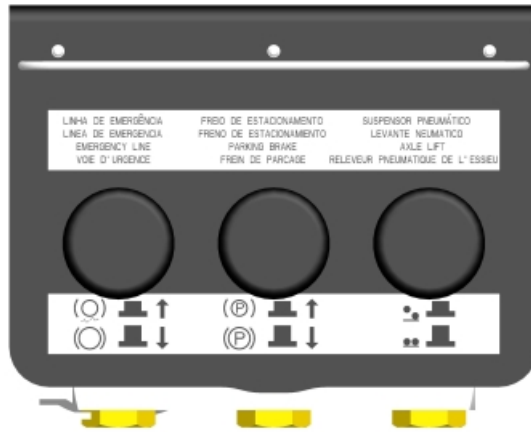

Valves	Operation	Function
Emergency Line	Press to release	To move the trailer when it is not coupled to the truck-tractor.
	Pull to activate	
Parking Brake	Press to release	To engage the parking brake of the semi-trailer.
	Pull to activate	
Air Axle Lift	Press to lift	To lift the semi-trailer axle (if equipped with air axle lift).
	Pull to lower	

With the Semi-Trailer Coupled

Before driving the semi-trailer away, drain the semi-trailer by means of the parking valve (ind. 8).

When parking, brake mechanically the semi-trailer by means of the parking valve (ind. 8).

With the Semi-Trailer Uncoupled

When uncoupled, the semi-trailer should have the brakes applied. The pneumatic system features valves that control the parking brake, either applying or releasing the brakes in case you need to move the semi-trailer when it is uncoupled from the tractor-truck.

Braking the Semi-Trailer when Uncoupled

When the semi-trailer is uncoupled, the emergency relay valve (ind. 3) of the semi-trailer operates its emergency function, applying all the brakes of the semi-trailer, but even so it is necessary to brake it mechanically.

To do this, turn the parking valve (ind.8) to PARK position, which will mechanically brake the semi-trailer by means of the spring brake chambers. Then, activate the movement valve button (ind.7).

Moving the Semi-Trailer when Uncoupled

To move the semi-trailer when uncoupled, the button of the valve responsible for releasing the semi-trailer (ind.7) must be pressed down and then the parking valve must be activated (ind.8) in order to release the brakes of the semi-trailer.

Coupling the Semi-Trailer

When coupling the semi-trailer, the valve responsible for releasing the semi-trailer (ind. 7) is activated automatically when the signal coming from the tractor-truck emergency line is received. Therefore, you have only to release the spring parking brake by means of the parking valve (ind.8).



Before releasing the parking brake of the semi trailer, check if the parking brake of the truck is activated.



Note:

- For all functions of the brake pneumatic system of the semi-trailer to function correctly, the air reservoir should have a minimum pressure of 7 and maximum of 10 bar (please note indication on the sticker).
- The performance of the semi-trailer pneumatic system depends on the pressure delivered by the tractor-truck, as well as on the quality of the air sent.



Attention:

When, for any reason, the air pressure drops beyond the minimum, the pneumatic system will activate automatically its emergency function, rear the semi-trailer.

BRAKE SYSTEM

Make sure that the pressure is between 8 and 10 bar to operate the air brake system



Cares to be Taken with the Brake Pneumatic System

In the Interlink Semi-trailer, all recommended cares shall be taken in both the front and back-up semi-trailers.

- Drain the air reservoir daily before releasing the semi-trailer. To this end, activate the air-drain valve (ind.11), located at the lower part of the air reservoir.



Attention:

accumulation of water in the air reservoir damages the components of the pneumatic system

- Check the air hoses (ind. 15) that connect the tractor-truck to the semitrailer daily;
- Check and clean, on a weekly basis, the filter (ind. 13) located at the emergency line next to the valve responsible for releasing the semi-trailer (ind.7) and replace it when necessary;
- Check the sealing rings (ind. 12) of the air couplings (ind.2) monthly and replace them when they show wear, cracks or air leakage;
- Check the flexible hoses (ind.16) connecting the quick relief valves (ind.4) and the brake chambers (ind.5) monthly;
- Test monthly the functioning the emergency relay-valve (ind.3) when the brake system is working. In case there is leakage or malfunctioning, visit immediately one of the RANDON Authorized service outlets;
- Check possible air leakage in the quick-discharge valves (ind. 4) when the brakes are applied. In case of leakage, replace the diaphragm (valve repair).



Note:

RANDON recommends performing overhauls and maintenance services on the pneumatic system at one of RANDON Authorized service outlets.

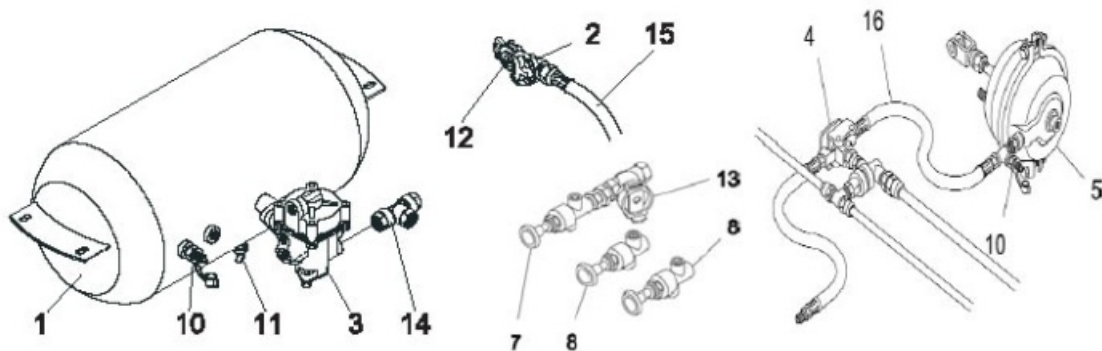

HPC System (High-Performance Concept)

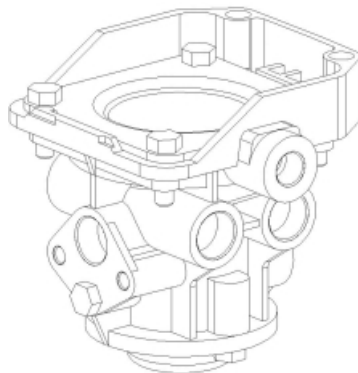

Randon equips its double-type trailers with the HPC system. This system has been designed to provide better distribution of the braking force to the trailers, with the following advantages:

- Increase in the efficiency level of the brake;
- Time reduction in brakes response;
- Braking balance with the other semi-trailers in case of compositions;
- Simplification in brake system components, freio (it is not equipped with quick-relief valve);
- Allows interchangeability of equipment without affecting the brake performance in case of compositions;



Comment:

For trailers equipped with the HPC system, Randon recommends that you use Randon original valves only, since there is a performance difference in relation to similar valves found in the market.

Load-Sensing Valve

The load-sensing valve, located in the dolly, is responsible for adjusting the service brake pressure to any loading condition of the vehicle, as long as the load capacity specified for the vehicle is respected.

All trailers/semi-trailers leave the factory with the valve properly adjusted. When you need to make any repairs and/or replacements, contact the Randon Service Dealer nearest you.

Carefully follow the procedures recommended for operation of the load sensing valve:

A position = Releasing Position (Dolly and the second semi-trailer without brake);

B position = unloaded (use this position when only the previous semi-trailer is loaded and under low-friction road conditions);

C position = Half-loaded position (use this position when only the previous semi-trailer is loaded);

D position = Loaded position (Use this position when both semi-trailers are loaded, or when both semi-trailers are unloaded).

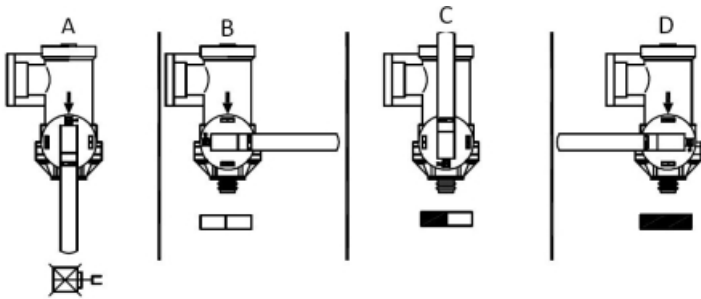

ELETRICAL SYSTEM

The electrical system is intended to signal the front and rear semi trailer when braking, indicating directions, alerting and signaling at night. The system connects the truck-tractor to the semi-trailer by means of connections and electrical cable.

The electrical systems of RANDON trailers and semi-trailers comply with the current traffic legislation and are tested and approved in their original configuration, according to resolution 294/08 of CONTRAN.

Its basic composition is:

- Electrical harnesses protected by plastic hoses;
- 7-pole electric plug (standard);
 - Electric outlet male (ind.3);
 - Electric outlet female (ind.4);
- Rear lights (ind. 1);
 - Position lights;
 - Brake lights;
 - Turning lights - right and left (blinkers);
 - Back-up lights
- Reflecting lights (ind. 6);
- License plate lights (ind. 5);
- Triangle-shaped reflective lights;
- Internal lights for vans.



Attention:

The perfect lighting system contributes to a reduced accidents rate. COOPERATE!



The connections and meanings of the electric connection plugs are:

Nº	Location/ Description	Wire Color
1	Body (ground)	White
2	LH rear side position	Black
3	Left turning	Yellow

4	Brake	Red
5	Right turning	Green
6	RH rear side position	Brown
7	Rear light	Blue

For system electric with lamps, use the powers listed below:

Light license plate: 2W - Light side position: 5W - Light rear position:10W - Light side direction: 10W - Light rear direction:15W - Light Brake: 15W - Light rear:21W



Important:

- Check harnesses and lights monthly;
- Keep the electrical connections always clean;
- Keep the same power and voltages when replacing lights.
- Bear in mind that the good performance of the system depends on the electric power (voltage / amperage) conditions, which are provided by the truck-tractor.



Attention:

For 24-volt truck tractors with LED recognition problems, a LED recognition kit shall be mounted on RANDON Distributors Network only, when the need arises.



Comment:

To clean the rear module and rear lights, use only mild soap and water. Do not use abrasive materials.

SEMI-TRAILER COUPLING SYSTEMS

The coupling of the front and / or rear semi-trailer to the tractor-truck is made by means of the fifth-wheel and a flanged 2" king-pin (Standard NBR NM ISO 337), or flanged 3.1/2" king-pin (NBR NM ISO 4086), guaranteeing coupling to any fifth-wheel of the same size.



Attention:

RANDON recommends taking special care regarding these components, as they support all the traction load of the set semi-trailer and tractor-truck.

Adjustments in the Coupling System

The locking mechanism of the fifth-wheel and king-pin is, according to the use to which the tractor-truck is exposed to and to the service level it receives, subject to wear. Wear is shown through slack movements inside the locking mechanism.

The locking device of the JOST fifth-wheel features manual adjustment to compensate for wear and extend its durability.



Note:

In the Interlink semi-trailer, all instructions shall be followed in both the front and rear semi-trailers.



Important:

Before adjusting the lock jaw, measure the wear of the king-pin and wear of the locking assembly, as shown in the figure. When the minimum values are reached, the components should be replaced.

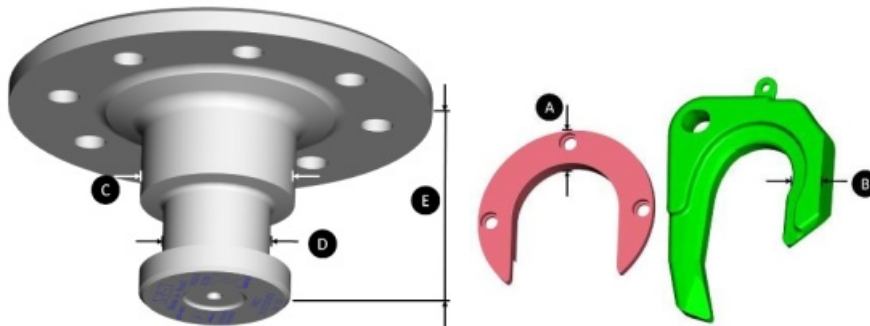

	2" KING-PIN		2" LOCKING SET		3.1/2" KING-PIN		3.1/2" LOCKING SET	
	MINIMUM (mm)	NEW PART (mm)	MINIMUM (mm)	NEW PART (mm)	MINIMUM (mm)	NEW PART (mm)	MINIMUM (mm)	NEW PART (mm)
A dimension			30,50	33,50			36,00	38,00
B dimension			17,50	19,00			35,50	37,00

C dimension	71,00	73,00			112,00	114,00		
D dimension	49,00	50,80			86,00	89,00		
E dimension	82,50	84,00			72,00	74,00		

After replacing the king-pin, check for slack in the king-pin locking system as follows:

- Couple the semi-trailer to the tractor-truck;
- Start the tractor-truck with the brakes of the semi-trailer applied, checking if there is still slack in the locking system of the fifth-wheel with the king-pin;
- If the slack persists, it is an indication that the locking system components of the fifth-wheel need adjustment or are worn. In this case, re-adjust correctly or replace the worn components of the fifth-wheel.

Procedure to adjust slack in the JOST fifth-wheel model SK 37C

- Loosen the regulating screw (bolt) and the nut;
- Unscrew the regulating screw (bolt) until it does not touch the top of the locking bar any longer;
- Hit slightly on the handle rod so the locking bar reaches its final position;
- Keeping the handle pressed forward, turn the regulating bolt to the right (clockwise) until the handle starts to move out, then screw (bolt) the adjusting bolt 1 ½ turn clockwise check it.

Procedure to adjust slack in the JOST fifth-wheel SK 38 C1 and SK 38 C1-2

- Loosen the nut and the screw (bolt);
- Hit slightly on the handle rod so the locking bar reaches its final position;
- Tighten the turn until any slack between the levers is eliminated and in such a way that only the locking bar can move;
- Tighten the screw one turn and then tighten the nut.

Maintenance Instruction



Note:

In the Interlink Semi-trailer, all instructions shall be followed in both the front and rear semi-trailers.

1. Uncouple the semi-trailer at least once a week or after 5,000 km in order to:
 - Clean the semi-trailer pick-up plate and the upper plate of the fifth-wheel;
 - Lubricate the top plate, the locking mechanism, the lock of the fifth-wheel and the king-pin. Use grease recommended by RANDON;
 - Check the crank handle and release the lock to allow free movement. Clean and lubricate

2. Inspect monthly the coupling system:

- For deformation or cracks on the fifth-wheel, king-pin, pick-up plate and bolts;
- Replace the king-pin whenever wear exceeds the minimum measure allowed. RANDON does not recommend re-using the worn king-pin, even if it is re-positioned;
- Keep the bolts (ind. 2) of the king-pin (ind. 1) duly tightened;
- Check the torque on the screws of Ø2" king-pin (torque of 18-20 kgf.m);
- Check the torque on the screws of Ø3.1/2" king-pin (torque of 26-28 kgf.m);



Attention:

Check king-pin fastening on a weekly basis



Note:

Replace all the bolts (ind. 2) whenever you disassemble or replace the king-pin.

Use only original bolts according to 10.9 grading.

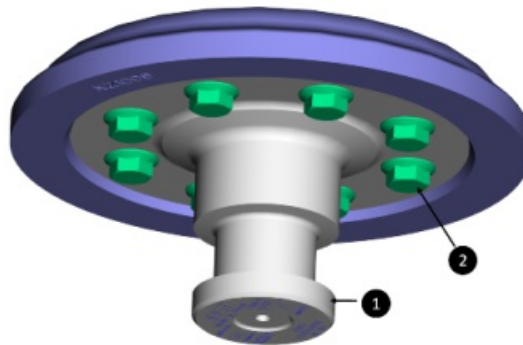

Coupling Procedure

The coupling procedure described below refers to equipment fitted with JOST fifthwheel and flanged king-pin.

Notes regarding the Interlink Semi-Trailer

All coupling maneuvers shall be performed in both the front and rear semi-trailers.

The unloaded semi-trailers can be coupled and/or uncoupled either together or individually to and/or from the tractor-truck.

Coupling the Semi-Trailer:

- The semi-trailer must be on a flat and regular surface;
- Release the lock (ind. A) of the crank handle (ind. 1);
- Prepare the fifth-wheel for coupling the king-pin by pushing the crank handle (ind.1) forward (ind.B) and unlocking it (ind. C). Then pull all the way out (ind. D).
- Causing the crank handle to be approximately 350mm out;
- Check the height of the pick-up plate and the fifth-wheel upper base. The plate should be approximately 50mm lower. This procedure must be followed mainly in equipment fitted with pneumatic suspension (air springs), since any pressure loss can change these measures;
- Back up the tractor-truck slowly and perform the lockup. The fifth-wheel mechanism will lock automatically;

- Make sure the pick-up plate base is fully backed on the fifth-wheel base plate and that the crank handle (ind. 1) is fully retracted;
- Connect the pneumatic system hoses and the electrical cable;
- Apply the semi-trailer brake and make sure that lockup was duly performed by driving a little forward;
- Retract the landing-gear;
- Release the parking brake.

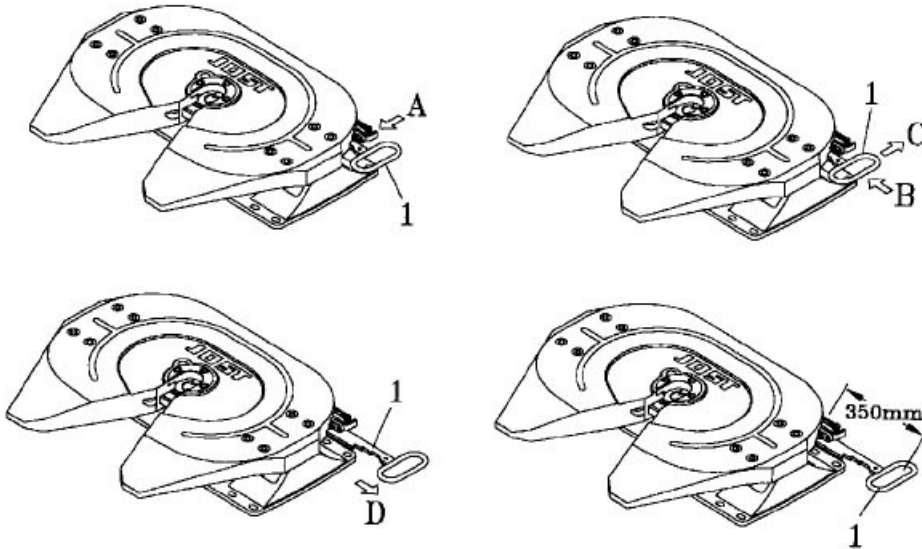

Attention:

Move the semi-trailer only after making sure that lockup was performed. Check also if the brake and the electrical systems are functioning well.

Uncoupling the Semi-Trailer

- Position the semi-trailer on a flat and regular surface;
- Lower the landing gear according to specific instructions;
- Disconnect pneumatic system hoses and the electrical cable;
- Release the lock (ind. A) of the crank handle (ind. 1);
- Push the crank handle (ind. 1) forward (ind. B), unlocking it (ind. C). Then pull it all the way (ind. D), causing the crank to be approximately 350 mm out;
- Drive the tractor truck away slowly. The fifth-wheel mechanism will perform the lockup automatically (ind.D).



Attention:

The Interlink combination has been designed and structured to be used with the two semi-trailers coupled to each other, that is, forming a set and thus allowing a greater CGVW (total combined gross weight) according to traffic legislation. If the units are used separately, the front semi-trailer, if loaded, may overturn when being uncoupled from the tractor-truck, since it has not been designed to be used this way.

In the Interlink, the position of the landing gear on the chassis, allied to the position of the gravity center of the front semi-trailer, may pose the same risk when being uncoupled, if loaded.

In order to avoid the risk of accident / overturning of the front semitrailer, RANDON determines that it may not be uncoupled from the rear semi-trailer when loaded and when not coupled to the tractor- truck.



Note:

On soft grounds, RANDON recommends the use of transversal boards underneath the landing gear shoes, preferably wider than the landing gear shoes.



Note:

RANDON does not recommend to use weld on the fifth wheel either in its components, otherwise it may cause bad performance of the equipment and you could lose the warranty.

Maintenance

Check the wear block of fifth-wheel block. If wear block is comes to the level lubrication groove (ind. A) at any point, the block must be replaced. In the shaded area (ind. B), is acceptable the wear until 8 mm, which can be measured from 3 mm below lubrication groove.

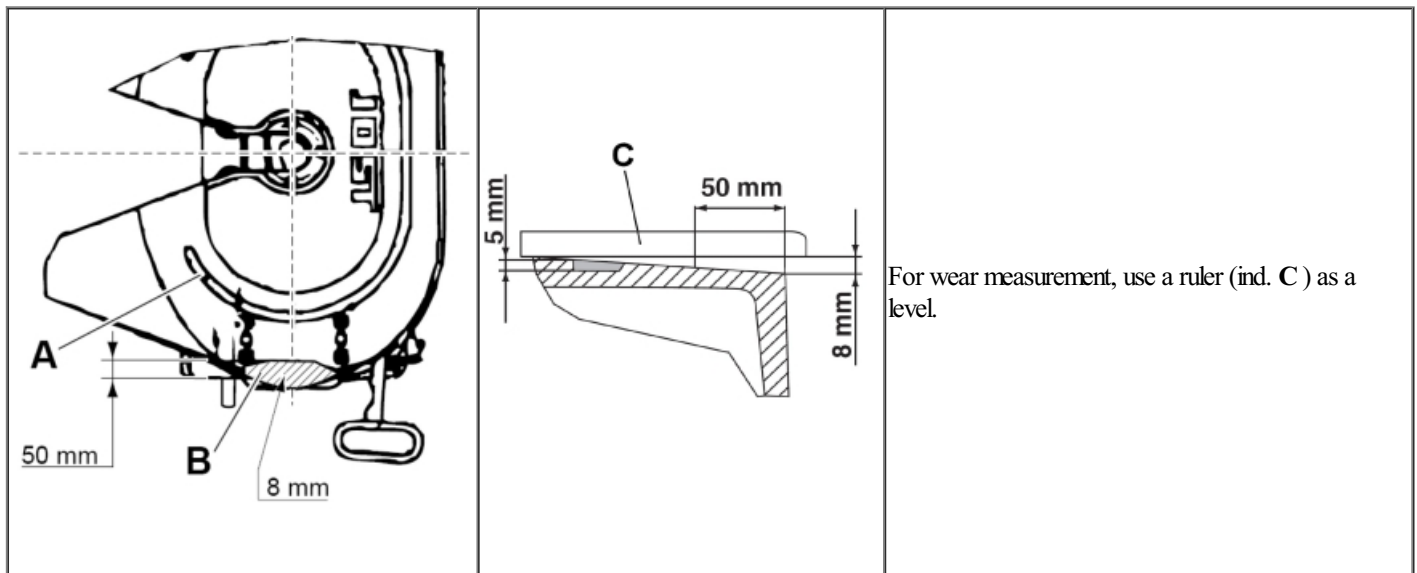

Turntable

The coupling of the trailer to the tractor-truck is made by means of the coupling fixed on the rear of the tractor-truck and the towing bar of the trailer drawbar.

Special care should be taken with these components, as they are the components supporting all the driving load of the coupled set.

RANDON recommends that you, before releasing the equipment away:

- Check the pneumatic and electric system couplings, as well as the tractor-truck and trailer coupling;
- Check the coupling safety system. Keep the safety chains always coupled, if fitted with this system;
- Do not uncouple the trailer on improper places, uneven or irregular ground or on soft ground;
- Do not uncouple the trailer before releasing the safety chains first;
- Do not move the tractor-truck before making sure that coupling procedure was duly performed.

Trailer Articulation System

The articulation of the trailer front suspension is made by means of the JOST turntable, which is fitted with a sliding system by means of rollers.

RANDON recommends that you do the following:

- Check monthly the articulations of the drawbar and if the turntable is functioning properly, making sure there is no slack;
- Check monthly the turntable fastening by re-tightening the screw (ind.5);
- Lubricate the turntable weekly or every 5,000 km through the lubrication nipples (ind.1) located all around.

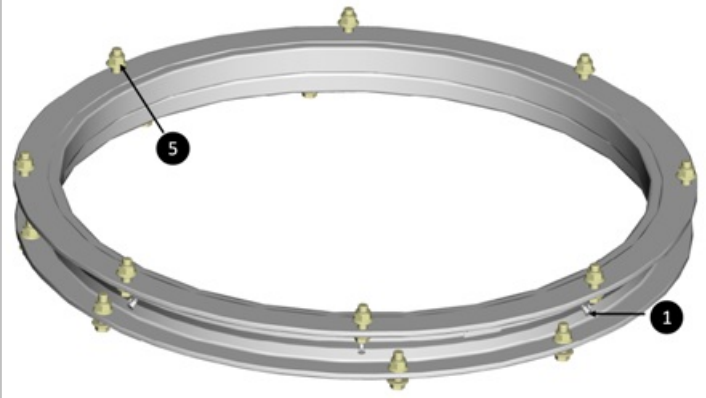

Note:

Depending on the utilization or on the working conditions, lubrication must be performed at earlier periods.

Lubrication of the Turntable

- Inject grease in all lubrication nipples until leaking through the rings;
- Turn the turntable approximately 20 degrees and inject;
- More grease until leaking;
- Repeat the procedure until the turntable gets fully lubricated;
- Use only grease recommended by RANDON.

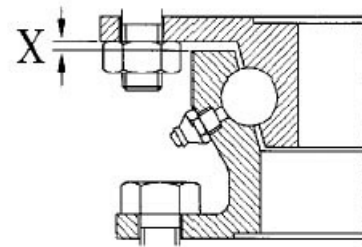

Maintenance of the Turntable

The turntable is a component subject to wear. The limit of wear is reached when the axial slack between the upper and lower rings, which is of 3,5 mm, reaches 0 mm (zero) in any point of the turntable circumference (see dimension X).

The screws torque must be ensured whenever the equipment is operating. To this end, as a maintenance item, the torque must be checked monthly so as to ensure it is within the specified torque of **27 to 31 Kgf·m**, according to the following torque sequence:

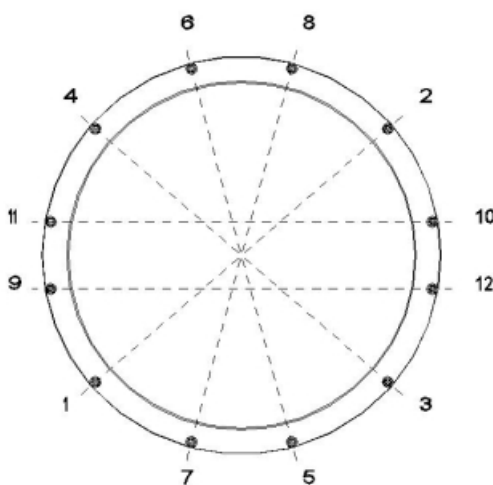

Rala 26t.

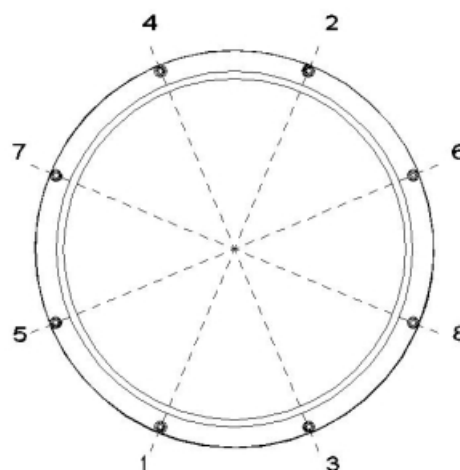

Rala 16t.



Attention:

FOR TRAILERS/SEMI-TRAILERS AND TRUCK-TRACTORS WITH COUPLING TO TRAILERS AND DOLLIES, CAREFULLY FOLLOW THE OPERATING PROCEDURES AND MAINTENANCE PLANS RECOMMENDED BY RANDON, AS DESCRIBED IN THIS MANUAL, THAT IS, ALL CONTENTS OF THIS MANUAL (INCLUDING INFORMATION IN THE WARRANTY CERTIFICATE UP TO THE TRAILER/SEMI-TRAILER PAINTING) IS VALID FOR TRAILERS/ SEMI-TRAILERS AND DOLLIES.

Towing bar

Draw-bars for the towing hitch coupling are manufactured from forged and tempered material. Drawbars are available with or without wear bushing, with eye profile in compliance with DIN 74053-1 Standard. Perform maintenance procedure as indicated:

- Whenever you replace the towing bar, replace also the nut (ind.6);
- Check monthly the adjustment of the nut, item 6, certifying it self of the slack between inexistence.
- Lubricate the towing bar weekly or every 5,000 km (ind.3)through the lubrication nipples (ind.4).
- Periodically check the maximum wear limits of the drawbar and bushing.

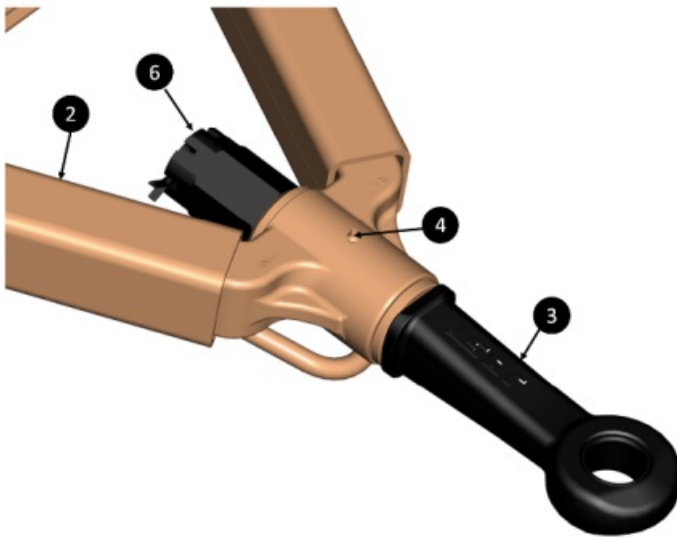

If the drawbar wear limit is exceeded, it should be replaced.

The table below presents the dimensions of the new drawbar and the maximum wear limits allowed for drawbars:

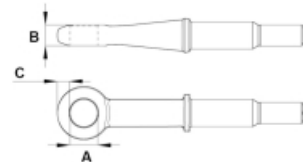

Size	Drawbar with bushing		Drawbar without bushing	
	New Part	Maximum Wear	New Part	Maximum Wear
A – bushing	50,50mm	52,50mm	50,00mm	52,00mm
B – eye	45,00mm	41,50mm	45,00mm	41,50mm
C – eye	27,50mm	23,50mm	32,50mm	28,50mm

Trailer Turning Angle

Whenever you perform a backwards operation (reverse), care must be taken not to exceed the maximum opening angle (75 °) of the coupler jaw, or not to hit the bumper brackets, as it will damage the parts of the assembly or will jeopardize the entire coupling and articulation system of the

trailer. Follow the table below:

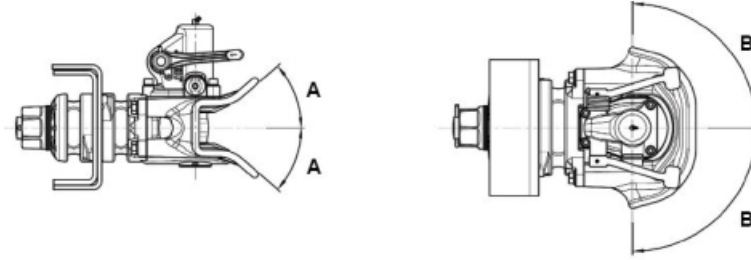

Legenda	Drawbar Free Angle	Maximum angle with deflection of cushions
A	10°	20°
B	75°	90°



Attention:

The horizontal working angle is 90 degrees for each side, according the previous image, but these degrees changing according the segment. Below exists a table with segment and the maximum angle accepted.

Segment	Angle Horizontal
Sugarcane	90°



Automatic Coupling

The Towing Hitch is aimed at coupling truck-tractors to trailers and dollies. Carefully follow the operation instructions and maintenance plan recommended by Randon.

**Note:**

There is no need to use grease between the pin and the drawbar towing bar when using this coupling.

**Important:**

The towing hitch has been developed to mount on cross members of up to 25.4 mm thick. If the application is for smaller-thickness cross members, shims should be used for compensation.

Trailer Coupling Maneuvers

Below we describe guidelines recommended by RANDON for the coupling and uncoupling operations of the trailer.

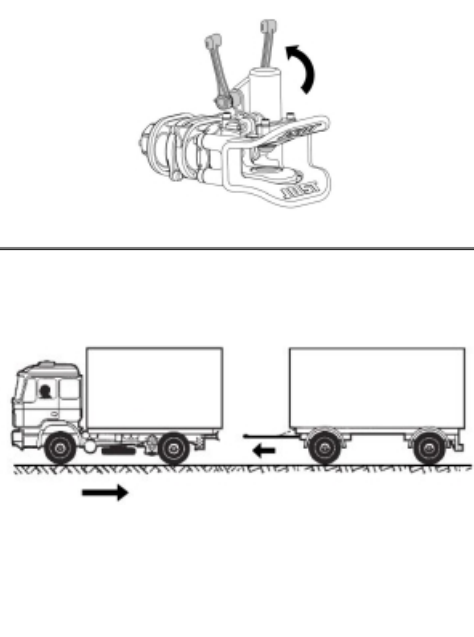
<ul style="list-style-type: none">• Approach the truck-tractor to the trailer;• Pull both levers up until they are upright. This will lift the pin and make the towing hitch ready for coupling;• Level the trailer drawbar until the drawbar is at the height of the truck-tractor coupling;• Slowly pull back the truck-tractor until coupling is carried out. Usually the truck-tractor coupler is equipped with an automatic coupling system, dispensing with the manual completion of this task. In case it is equipped with a manual device, carry out the additional tasks;• Check if the coupling has been successfully made;• Connect the pneumatic system hoses and the electrical cable;• Engage the safety chains, if this system is in place;• Release the parking brake of the trailer.	 <p>The diagram is divided into two parts. The top part shows a close-up of the truck-tractor coupling mechanism, with a curved arrow indicating the upward movement of the levers. The bottom part shows a side view of a truck and a trailer on a road. An arrow points from the truck towards the trailer, and another arrow points from the trailer towards the truck, indicating the relative movement during coupling.</p>
--	--

**Note:**

Before performing the coupling operation, make sure that the wheels of the trailer are locked, although the steering axle shall remain free to allow the drawbar to slide into the towing hitch, thereby performing the coupling.

**Important:**

The towing hitch is provided with a safety pin system with a locking indicator. After each coupling, make sure the pin on the side of the towing hitch is fully retracted. This indicates that the coupling pin is properly locked. If after the coupling the lock indicator pin is still out of the housing, this means that the coupling has not been properly performed.

Uncoupling the Trailer:

- Part the trailer on a flat and compact place;

- Apply the trailer parking brake and prop up the trailer;
- Disconnect the pneumatic system hoses and the electric cable;
- Uncouple the safety system (chains);
- Release the coupling device;
- Move the tractor-truck forward slowly, concluding the uncoupling operation.

Cleaning, lubrication

The towing hitch moving parts are subject to wear and tear due to operation and application conditions. For the coupling assembly to last longer, it is recommended that every six months the towing hitch locking mechanism should be disassembled so that the movable parts may be cleaned and lubricated. Use heavy-duty grease (EP), lithium-soap based and extreme pressure additive.

On a weekly basis, clean the locking pin and the bushings to prevent the formation of abrasive element which increases wear on the components. Clean also the trailer drawbar eye.

Maintenance

A weekly visual check should be carried out for cracks in the towing hitch components. A measurement should also be performed of the coupling pin and bushings to check the wear limit. The wear maximum limits allowed for the pin and bushings are described in the figure below:

	Item	New Part	Maximum Wear
	A - Bushing top	49.1mm	51.6mm
	B - Bucha botton	43.2mm	45.7mm
	C - Pin	49mm	47.5mm
	D - Pin	48.7mm	46.5mm
	E - Pin	43mm	41.5mm



Comment:

When checking the wear limit of the coupling pin, measure at several points since the pin is subject to irregular wear in its circumference.

Spherical Coupling for Coupling the Dolly to a Fixed Drawbar

This dolly is fitted with a fixed drawbar (ind.1), providing greater applying stability in curves or maneuvers. It is also fitted with a pneumatic axle lift in the first axle, which avoids the use of the tires when the equipment travels unloaded.

As the fixed drawbar of the Dolly is an extension of its chassis, there is an auxiliary landing gear (ind.2) that facilitates coupling and uncoupling.

The Spherical Coupling of the Dolly with the fixed drawbar transfers a larger vertical load to the coupling of the semi-trailer. The spherical coupling has been specifically designed to stand this vertical load and is suitable for the coupling of this type of Dolly. The spherical coupling allows the towing bar of the dolly to move in any direction (without slack), meeting international standards. This way, the durability of the towing bar and

coupling is longer, reducing maintenance costs and increasing the stability of the coupling operation.

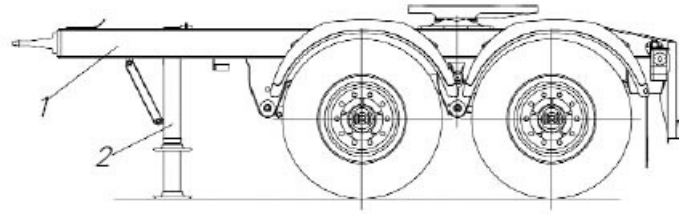

Attention:

The spherical coupling is not automatic. Therefore, please be aware that it is necessary to release the nuts and the screw connecting the towing bar to the spherical pin when uncoupling the Dolly. For correct coupling and uncoupling operations, please follow instruction on the right and the ones written on the sticker fixed next to the coupling.

RANDON

ATENÇÃO

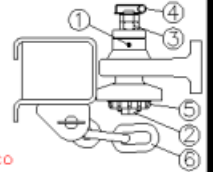

- 1 - Manter o pino esférico sempre lubrificado.
- 2 - O parafuso central não deve sofrer aperto.
- 3 - A porca e contra-porca devem ser apertadas entre si.
- 4 - Manter a joaninha sempre encaixada.
- 5 - Periodicamente verificar aperto da porca castelada.
- 6 - Manter sempre a corrente de segurança engatada.

Coupling the Dolly:

- Approach the front semi-trailer to the Dolly;
- Raise the drawbar towing bar of the Dolly to above the spherical pin with the aid of the landing gear;
- Back up the front semi-trailer until the drawbar towing bar (ind.8) is aligned with the spherical pin (ind.1);
- Lower the drawbar over the spherical pin with the aid of the landing gear;
- Mount the central turn (ind.2), upper closing (ind.7), locking nuts (ind.3) and tighten until eliminating slacks. Place the nut locking safety pin (ind.4) (follow the indications on the sticker):
- Couple the safety chains (ind.6);
- Connect the hoses of the pneumatic system and electric cable;
- Release the parking brake of the dolly (drawing electric coupling).

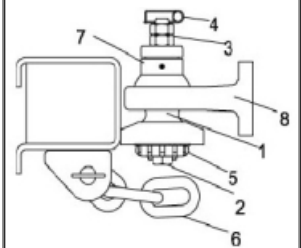

Uncoupling the Dolly

- Park the semi-trailer on a flat and compact ground;
- Apply the parking brake of the Dolly;
- Disconnect the pneumatic system hoses and the electric cable;
- Disconnect the safety chains (ind.6);
- Remove the the safety pin (ind.4) responsible for locking the nuts, release the nuts (ind 3), disassemble the upper closing (ind.7) and the central screw (ind.2);

- Raise the drawbar towing bar (ind.8) of the Dolly above the spherical pin (ind.1) with the aid of the landing gear;
- Move the front semi-trailer forward slowly, concluding the coupling operation.



Note:

Check regularly the tightening of the nut (ind. 5), whose torque must be between 40 and 43 kg.m

Maintenance Instructions:

The maintenance overhaul and periodicity must be followed according to the table below:

Downtime for Overhaul and Repair

Km limit for overhaul	Items to be inspected	Service to be carried out	Replacement Items
0 km and at every time a new coupling is made	Lubrication of the drawbar with the ball hitch and with the cushioning system	Lubricate, in case there is need for lubrication	EP2 extreme-pressure grease
First 1,000 km	Check for clearance in the castellated nut of the ball hitch (ind 5)	Check if the ball hitch is rotating on the cross member base	
Every 10.000 km	Check for clearance in the castellated nut of the ball hitch (ind 5)	Check if the ball hitch is rotating on the cross member base	

Automatic Ball Hitch for Coupling the Dolly with Fixed Drawbar

This Dolly features a fixed drawbar (ind. 1) which provides the set with extra stability during braking in curves and maneuvers.

It is equipped with an air axle lift in the first axle for economy of the tires when running unloaded.

Considering that the fixed drawbar of the dolly is an “extension” of its chassis, there is an auxiliary landing gear aimed at making the coupling and uncoupling procedures easier (ind. 2).

The ball hitch of the dolly with fixed drawbar transfers a higher vertical load to the semi-trailer towing hitch. The automatic ball hitch has been specifically developed to withstand this vertical load and is used for couplings with this model of dolly.

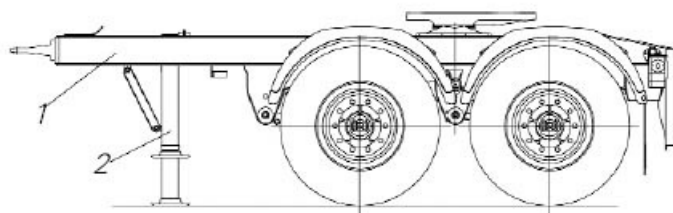

The automatic ball hitch allows the motion of the dolly drawbar in any direction (without clearance), in compliance with international standards. This way, the durability of the drawbar and towing hitch will be longer, reducing maintenance-related costs and increasing the stability of the coupling (hitch).

The automatic ball hitch features a cushioning system that significantly reduces wear on the components, in addition to improving the stability of the vehicle.

Its locking system makes coupling and uncoupling procedures between vehicles easier. The rotating coupling system with locking pin is practical and safe. Once the system is properly adjusted, the coupling operation becomes faster.

The Automatic Ball Hitch must be periodically lubricated and adjusted for its perfect performance, according to “Maintenance Instructions” contained in this Manual.

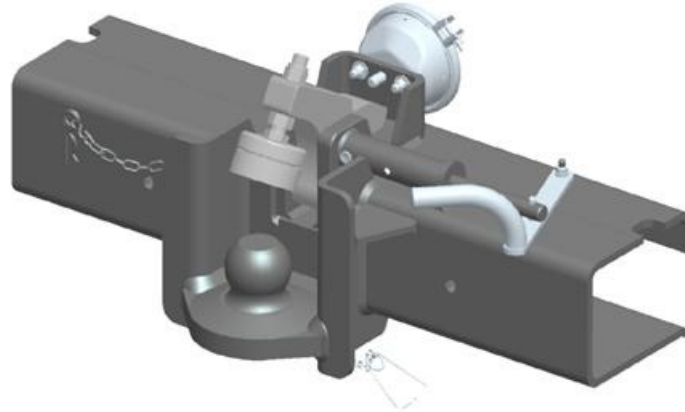

Adjusting the Working Pressure

In order to ensure that the proper lifespan of the components will be reached, as well as the safety of the coupling (hitch), make the first adjustment after running 1,000 km and then at every 10,000 km.

The automatic ball hitch must be adjusted together with the drawbar in order to calibrate the shock-absorber pressure with the cylinder of the activated pneumatic device.

With the drawbar mounted, activate the pneumatic device with the recommended pressure (7 to 9 bar), keeping the pressure in the line. After activating it, release the nuts and adjust the adjusting bolt so that the locking pin may slide freely in its housing. The system will be aligned when the pin is able to slide freely **with the pneumatic device activated**.

When the system is aligned, apply a torque to the nuts as indicated in the figure below:

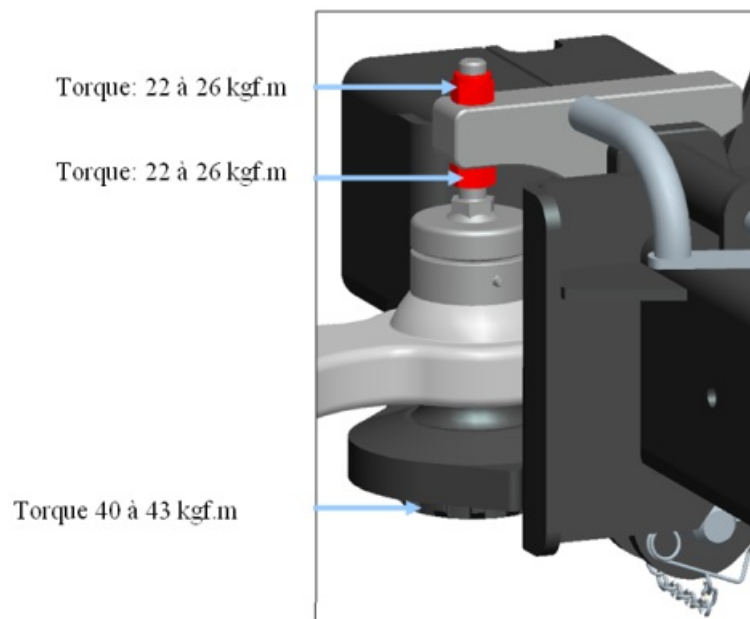

Attention:

When the pneumatic device is not activated, the pin WILL NOT slide freely, as the cushioning system will be in operation.

Never use welding on any area of the ball hitch.

Coupling the Dolly:

- Park the equipment on a flat and compact ground;
- Engage the parking brake of the dolly;
- Slowly approach the front semi-trailer to the dolly until the boom is aligned with the drawbar.
- Lower the dolly drawbar until the drawbar is completely anchored on the ball hitch. Do this with the aid of the landing gear;
- Activate the pneumatic device. This procedure will align the assembly holes of the safety pin;
- With the safety pin on the closed position, mount the cotter-pin of the locking system. In case it is not possible to mount the cotter-pin, push the pin until the mounting operation is complete;
- Disengage the pneumatic device and anchor the system with the safety chain. The pneumatic device SHALL NOT remain activated during operation;
- Connect the air system hoses and electric cable;
- Release the parking brake of the dolly.



Note:

The pneumatic device SHALL NOT remain activated during operation.



Attention:

When you are approaching the drawbar, the hook shall be in the open position to avoid shocks with the drawbar. In case this happens, the adjusting bolt can be damaged, compromising the safety of the vehicle.



ENGATE ESFÉRICO = Ball hitch

Acoplamento = Coupling

- 1 – Position the drawbar over the ball pin;
- 2 - Lower the coupling (hitching) system over the drawbar;
- 3 - Activate the pneumatic device;
- 4 - Place the safety pin on the closed position (A) and mount the cotter-pin (B);
- 5 - Disengage the pneumatic device and anchor the safety chain.

Desacoplamento = Uncoupling

Position the drawbar over the ball pin, lowering the dolly until the drawbar rests completely on the ball pin.

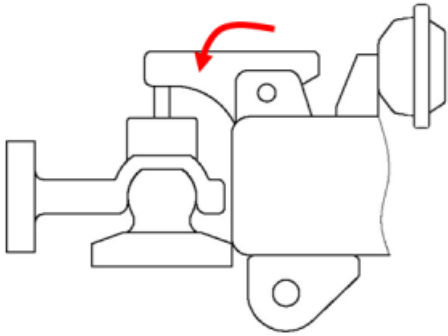
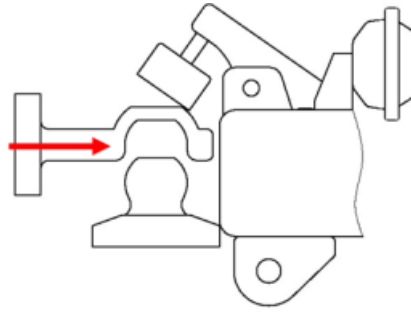

Lower the coupling system over the drawbar and check if it is well centered and seated.

Activate the pneumatic device. This will align the assembly holes of the safety pin.

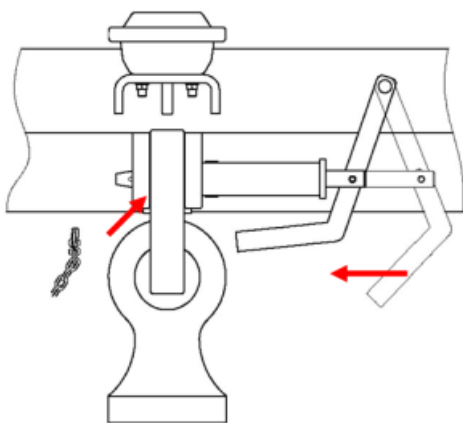
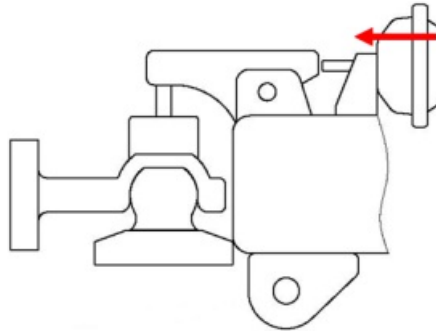

Position the safety pin on the closed position and mount the coupling system cotter-pin. In case it is not possible to mount the cotter-pin, push the pin until the mounting is complete.

Disengage the pneumatic device and anchor the system with the safety chain. The pneumatic device SHALL NOT remain activated during operation.

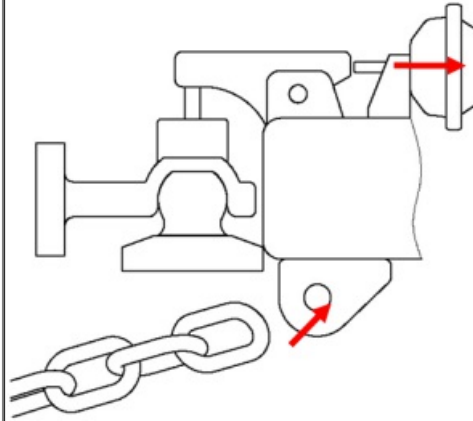

Uncoupling the Dolly:

- Park the equipment on a flat and compact ground;
- Engage the parking brake of the dolly;
- Slowly approach the front semi-trailer to the dolly until the boom is aligned with the drawbar.
- Disconnect the hoses from the air system and electric cable;
- Remove the cotter-pin from the locking system;
- Engage the pneumatic device and move the lever to the right until it reaches the buffer.
- Disengage the pneumatic device and raise the coupling system;
- Raise the dolly drawbar until the drawbar is completely free from the ball hitch. This can be done with the aid of the landing gear;
- Slowly approach the front semi-trailer, completing the uncoupling procedure;
- Lower the coupling system and move the lever to the left, until it is possible to place the cotter-pin into the safety pin.

Activate the pneumatic device and release the system with the safety chain.

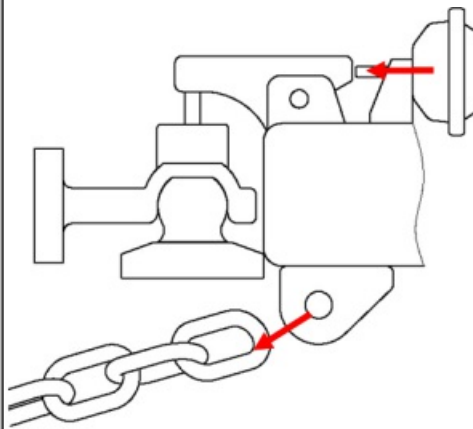

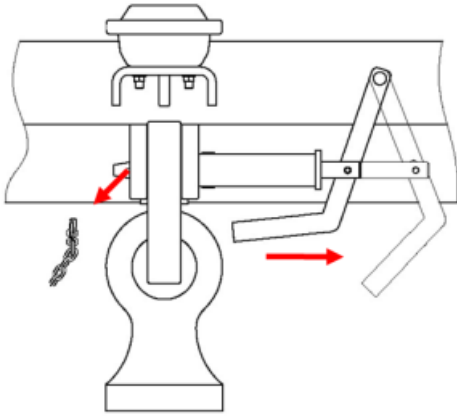

Remove the cotter-pin from the locking system and move the lever to the right until it reaches the buffer.

Release the pneumatic device

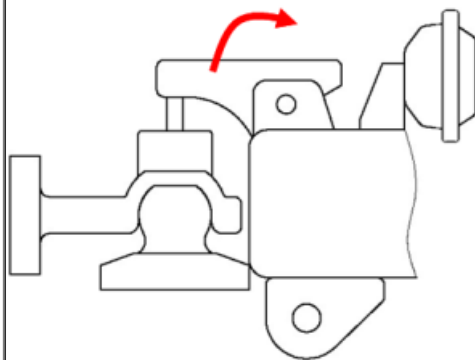
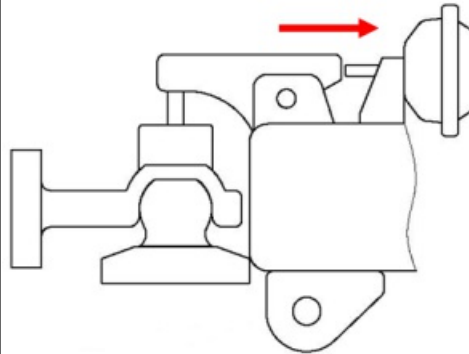

Open the coupling system over the drawbar.

Lift the dolly drawbar until the drawbar is completely free from the ball hitch.

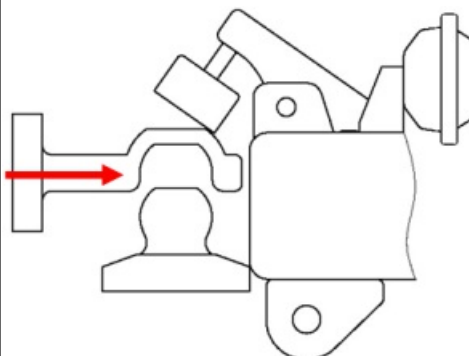

**Note:**

Never keep the pneumatic device open during operation.

Maintenance Instructions:

The maintenance overhaul and periodicity must be followed according to the table below:

Downtime for Overhaul and Repair

Km limit for overhaul	Items to be inspected	Service to be carried out	Replacement Items
0 km and at every time a new coupling is made	Lubrication of the drawbar with the ball hitch and with the cushioning system	Lubricate, in case there is need for lubrication	EP2 extreme-pressure grease
First 1,000 km	Adjustment of the cushioning system	Adjustment of the working pressure	
	Check for clearance in the castellated nut of the ball hitch	Check if the ball hitch is rotating on the cross member base.	
Every 10,000 km	Check for clearance in the castellated nut of the ball hitch	Check if the ball hitch is rotating on the cross member base.	
	Adjustment of the cushioning system	Adjustment of the working pressure	
	Lubrication of the locking pin	Lubricate the locking pin through the lubricator.	EP2 extreme pressure grease

Turning Angle - Ball Hitch for Fixed Drawbar

Whenever you perform any maneuver, either forward or backward (reverse gear), or operate the vehicle in areas with steep slopes or elevations, please observe the maximum permitted angles: horizontal (60°) and vertical (20°), thus avoiding the drawbar to hit the ball hitch, which would damage its components and undermine the whole locking system.

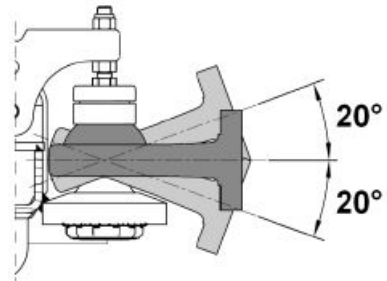
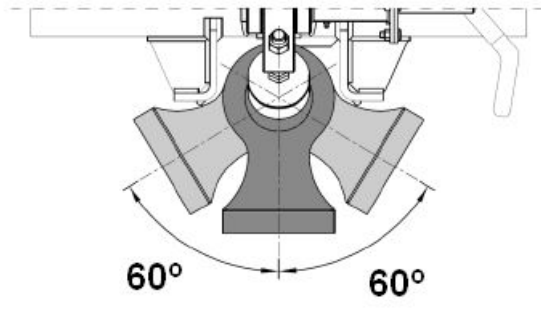

LANDING GEAR

The landing gear has the function of lifting the equipment in order to uncouple the king-pin from the fifth-wheel and support the equipment on the ground after the tractor-truck is uncoupled. RANDON semi-trailers may be equipped with Mechanical or Hydraulic Landing Gears.

Mechanical Landing Gear

RANDON trailers are equipped with JOST mechanical landing gears, which feature two operating speeds: a fast speed to approach the legs to the ground, and a slow speed to lift the load. The change of speed is made by means of the crank. Mechanical Landing Gears are available in two models:

- **B200 Series**

- **B280 Series**

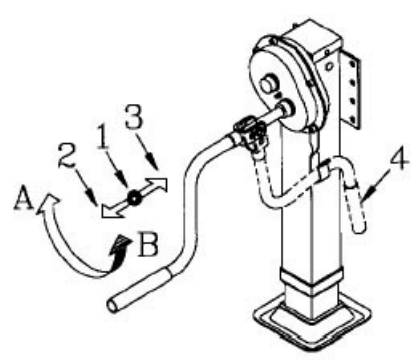
<p>B200 Series:</p> <p>Technical Features</p> <p>Lifting capacity: 24 ton.</p> <p>Static capacity (landing capacity): 50 ton.</p> <p>Lifting by turn: Low speed : 1,0mm</p> <p>High speed: 10, 6mm</p>	
<p>Landing Gear Crank</p> <ul style="list-style-type: none">• To retract the Landing Gear: Turn the crank anti-clockwise “B”.• To lower the Landing Gear Turn the crank clockwise “A”.	

B280 Series:

Technical Features

Lifting capacity: 28 ton.

Static Capacity (landing capacity): 50 ton.

Lifting by turn: Low speed: 0,65mm

High speed: 10,6 mm

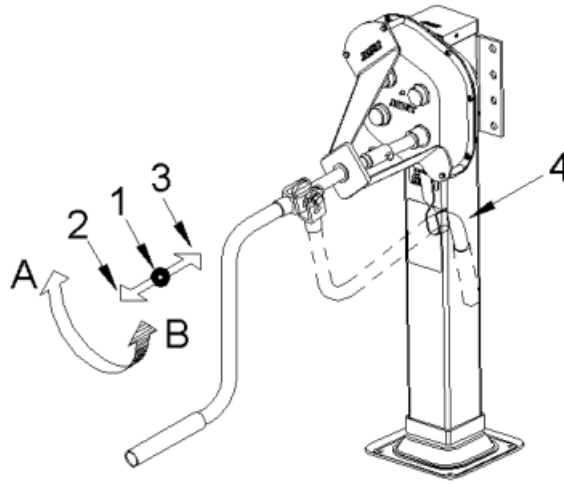

Landing Gear Crank

- **To retract the Landing Gear**

Turn the crank clockwise “ A ”.

- **To lower the Landing Gear**

Turn the crank anti-clockwise “ B ”.



Important:

Both models bear, on the RH leg, an identification plate and sticker with specific operating instructions.

Operating Instructions:

To retract the Landing Gear

After coupling the tractor-truck to the semi-trailer, according to specific instructions, do the following:

- withdraw the crank from its support (ind. 4);
- retract the landing gear in low speed (ind. 3) until the legs move off the ground by turning the crank according to instructions indicated in the landing gear series.
- change to high speed (ind. 2), retracting the legs by also turning the crank according to instructions indicated in the **landing gear series**;
- return the crank to its respective support (ind. 4) engaged on speed 2 or 3.

To Lower the Landing Gear

Before uncoupling the semi-trailer, observe the following:

- withdraw the crank from its support (ind. 4);
- engage the high speed (ind. 2), approach the legs to the ground by turning the crank according to instructions indicated in the landing gear

series;

- change to low speed (ind. 3) until you get the ideal height for uncoupling, also by turning the crank according to instructions indicated in the landing gear series;
- return the crank to its respective support (ind. 4), engaged on speed 2 or 3;
- uncouple the semi-trailer according to specific instructions for this operation

To avoid damaging the system, make sure that the weight over the landing gear is not greater than the landing gear capacity.

Indications on the figure:

1. Neutral position: intermediary position;
2. High speed: position of the crank on high speed. Use it only for approaching the legs to the ground and for retracting them after use;
3. Low speed: position of the crank on low speed. Use it to lift and lower it when loaded;
4. Locked position: when the vehicle is moving. The gear ratio must be on position 2 or 3.



Attention:

Lubrication: on normal conditions, lubricate the landing gear every 120 days or every 40,000 km (minimum).

Hydraulic Landing Gear

The RANDON semi-trailers equipped with Hydraulic Landing Gears may be actuated either mechanically or pneumatically.

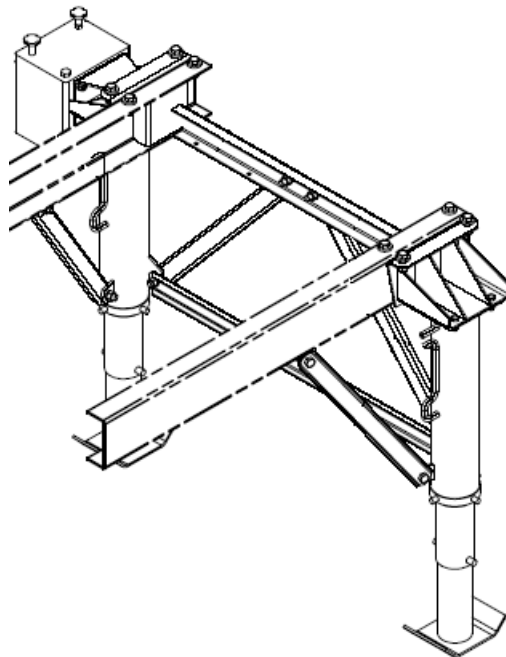

Operating Instructions:

Before operating your Hydraulic Landing Gear, read carefully the sticker placed on the hydraulic pump.

Technical Features

Lifting capacity: 32 ton.

Static capacity: (landing capacity): 50 ton with the nut locked.

**Important:**

For further information on the Landing Gear equipping your RANDON semi-trailer (operation, functioning and maintenance procedures), consult the RANDON`s Authorized Service Outlet nearest your.

**Attention:**

Do not uncouple the semi-trailer until the landing gear (both models) is fully rested on the ground, supporting all the weight of the semi-trailer. To this end, make sure it is leveled and/or on flat and even surface.

Pneumatic Axle Lift on the Third-Axle of the Semi-Trailer

For equipment fitted with pneumatic axle lift on the third-axle of the semi-trailer, we recommend:

- **Stability:** the more the suspension is trests on the ground, the better the stability, safety and braking conditions of the set. Therefore, when the equipment is with its two axles lifted, the driver must be twice as careful;
- **Maneuverability Conditions:** in rainy days, irregular or to sinuous roads, all axles should remain on the ground for safety reasons;
- **Speed:** When one of the axles or both axles are lifted, the driver must respect the speed limits and maneuverability allowed by the road, mainly for semi-trailers with higher gravity center, such as vans, siders, silos and others.
- **Weight:** When the equipment is loaded, all axles must remain on the ground not to cause overload on the suspension of the semi-trailer. Besides, the pneumatic axle lift is not designed to lift the axle when loaded, as in this moment the spring pack does not have elasticity to be lifted and its actuation can damage the suspension.



Attention:

- Only travel with the axle lifted when the semi-trailer is unloaded;
- Operating the pneumatic axle lift consumes a great amount of air. That is why we recommend using it only when necessary;
- The air filling the pneumatic spring (air bag) comes from the air reservoir. Therefore, the reservoir shall be full and with a minimum pressure of 5 bar.

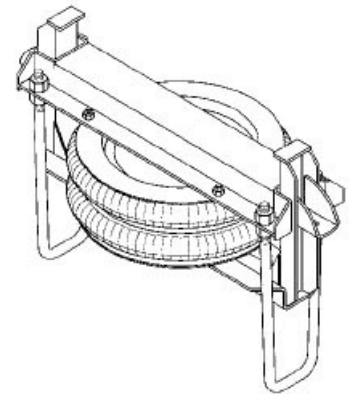

Instructions to operate the Pneumatic Axle Lift



Note:

In the Interlink Semi-Trailer, all instructions shall be followed for both the front and rear semi-trailers.

To lift the Axle:

- Actuate the axle lift valve (ind.1) located in the valve box at the suspension front to the position LIFT, according to instructions in the valve it self. The air will fill the pneumatic spring (air bag) which will, at the same time, lift the axle. The blocking valve (ind.2) blocks automatically the air passage to the axle brakes.

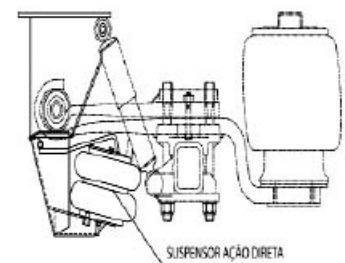
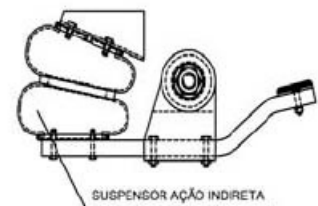

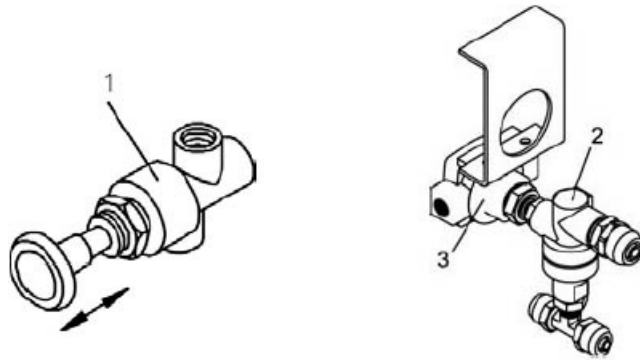

To Lower the Axle:

- Actuate the valve of the axle lift (ind.1) located in the valve box at the suspension front to the position LOWER, according to instructions in the valve it self. The pneumatic spring (air bag) will empty the air, causing the axle to go down. The blocking valve (ind.2) will drain automatically the normal flow of air to the axle brakes.



Important:

Even if the blocking valve (ind.2) controls automatically the air flow of the brakes, RANDON recommends checking the functioning of the brakes of the axle fitted with the pneumatic lift whenever you use the functions of the axle lift, making sure that:

- The axle does not get braked when lifted;
- The brakes are drain when the axle is lowered.



Attention:

Should the road equipment is fitted with a mechanical axle lift with a manual system to control the air flow from the brake, by means of the valve (ind. 4), follow the instructions below:

- The road equipment shall not have the brake applied when you operate the axle lift;
- Close the valve (ind. 4) whenever you retract the axle;
- Open the valve (ind. 4) whenever you lower the axle;
- Control the functioning of the brakes.

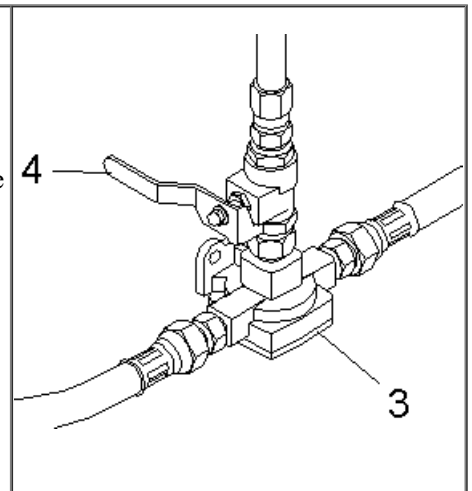

Pneumatic Axle Lift - PSYS

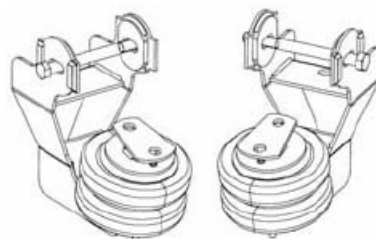

Product developed with a new design to guaranty a better action and durability of the **Direct Action Suspensor**.

Direct Action Suspensor presents answer more efficient in the axle lifting, with a major speed driven.

The mounting is done without the necessity of alteration of suspension components, maintaining originals configurations of semi-trailer suspensions.

- Nominal capacity of lifting is 1 ton.
- Free depth from floor in relation with the tires is approaching to 100 mm.



Attention:

the use of RANDON originals spare parts is indispensable. Any modification automatically shall invalidate the warranty.

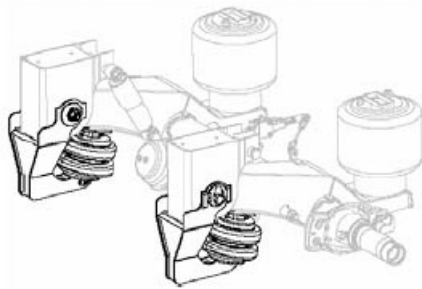

Operation Instructions

Don't operate the suspensor when there is only one of the sides is driving, due to a fail in the installation or for losses.

The pneumatic suspensor has the function of suspend the axle when the implement was without loading.

Don't recommend suspend the semi-trailer axle in rainy days, neither when is unloaded. With all the wheels on the floor the vehicle will have a major stability and insurance.

The ideal air pressure to job with the suspensor is 8,5 bar, letting a free depth of the wheels of 100 mm.

Maintenance Instructions

The pneumatic suspension ought to be verified on every vehicle revision and replace it when presents a deformation or loss.

The pivot screw must be replaced when it presents a wear upper than 1.5 mm in any place.

The chassis must be replaced when it presents marks provoked by strokes or swerve of material.



Note:

The use off RANDON originals spare parts is indispensable. To execute Reparations or Maintenances consult always in the RANDON Authorized Dealers Net.

Adaptations to Vehicle Manufacturers Revision Systems

You can adapt the periodicity of the "Maintenances - Periodical Maintenances Schedule" in order with the vehicle maintenance manual for the pneumatic suspensor installed, while don't exceed 5.000 km of difference and the period don't exceed 30 days from indication.

In case of adaptation, the overhaul foreseen in the "Maintenances - Periodical Maintenances Schedule" must do always in the overhaul more next to the foreseen by the vehicle manual.

EXAMPLE:

In case in -If in the vehicle manual is foreseen a detention for overhaul on 25.000 km and another on 45.000 km, must include the overhaul of 30.000 km foreseen in the table "Detentions for Overhauling and Reparation" in the overhaul of 25.000 km of the vehicle.

Problem Solutions

Defect	Cause	Solution

<p>The suspensor doesn't lift the axle.</p>	<ul style="list-style-type: none"> • Low air pressure (less than 7 bar) • Weight excess over the axle. • Mistake in the pneumatic installation. • Wrong position in the installation. 	<ul style="list-style-type: none"> • Increase the pneumatic system pressure before the axle lifting. • The axle weight is over the projected limit of 1 ton. • Overhaul the pneumatic installation. • Verify dimensions in order with the installation manual.
<p>Loss</p>	<ul style="list-style-type: none"> • Coupling of inlet air puts in bad order. • Perforated spring. • Perforated hoses. 	<ul style="list-style-type: none"> • Remove the nipple of inlet air, and put in order again. • Evaluate the thread of the nipple, if it presents wear, replace the nipple. • Replace the spring • Replace the hoses.



Note:

In the Interlink Semi-Trailer, all instructions shall be followed for both the front and rear semi-trailers.

Pneumatic Axle Lift - TAS

For the pneumatic suspension of the TAS model the pneumatic axle lift model as shown below is applied.

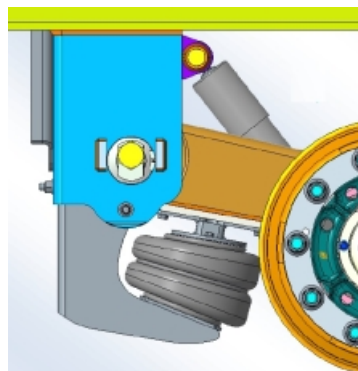

SPARE TIRE CARRIER

The semi-trailer is equipped with basket-type spare tire carrier (for two spare tires).

Instructions to fix the Spare Tire - For spoke Hubs

- Remove the handle (ind. 1) and the carrier fixing bar (ind.2);
- Place the spare tire (ind.3) making sure the smallest internal diameter of the tire band is faced downwards;
- Place the fixing bar (ind. 2) of the spare tire and fasten it properly by means of the handle (ind.1).

Instructions to fix the Spare Tire - For Disc Hubs

- Remove the handle (ind.1) and the fixing bar (ind.2);
- Place the spare tire (ind.3), making sure the wheel disc is faced upwards;
- Place the fixing bar (ind.2) of the spare tire, the fixing pin (ind.4) and fasten it properly by means of the handle (ind.3).

Instructions to withdraw the spare tire:

- Loosen the handle (ind.1) and withdraw the fixing bar (ind.2).
- Remove the spare tire (ind. 1).

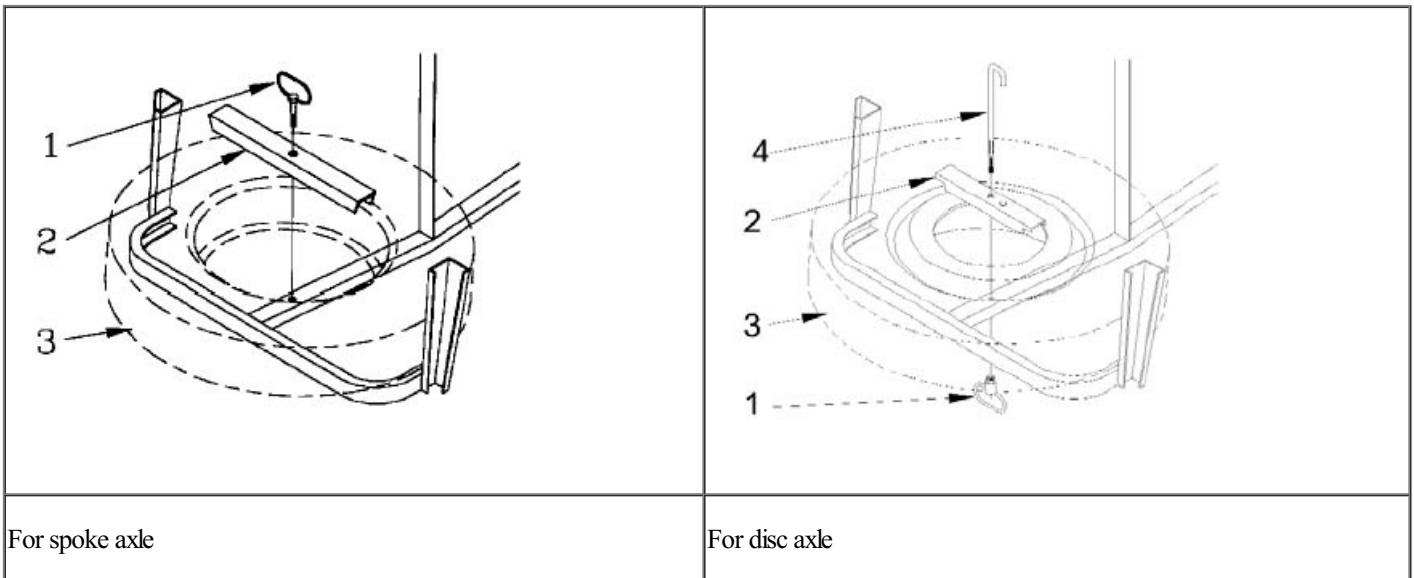

Comment:

In the interlink semi-trailer the spare tire is located only in the front semi-trailer.

Safety Retroreflecting Stickers

It is an accessory, whose utilization is mandatory, installed on the semi-trailer according to Regulation number 27/2001, of CONTRAN. The regulation determines the quantities and positioning of the stickers in various segments of road equipment.

Randon recommends installing, replacing and/or repairing the stickers in one of RANDON Authorized Service Outlets, thus avoiding non-compliance to Legislation in force.

Red	White (gray)
------------	----------------------

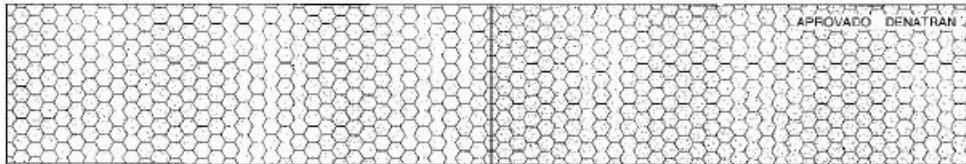

Hints on the maintenance and conservation of the stickers

Dirty Edges: dirt on the edges does not affect the performance of the product.

Therefore, do not try to withdraw it aggressively by using washing equipment by pressure, as it may cause the edges to lift and/or problems on the material laminate. Water temperature: maximum of 60°C.



Note:

After vaporizing the tank semi-trailers, we do not recommend washing the safety retro-reflecting device due to the heat.

Cleaning Solutions: Do not use acid-based solutions, alkaline solutions or solvents in general. We recommend using neutral solutions (pH between 6,5 and 7,5).

Cleaning

Wash your equipment regularly for maximum performance. The following washing procedures are recommended:

wash with a soft sponge or with a non-abrasive cloth, using tepid or cold water and detergent;

Automatic washing (stickers can be washed by automatic turning brushes);

Washing by pressure (1200 psi maximum, at a minimum distance of 30 cm and angle smaller than 45°);

Rinse your equipment thoroughly after washing it.

Pneumatic Axle Lift

It is an

OPTIONAL ITEMS

The following items are optional and are available for RANDON semi-trailers. Their installation always depend on the customers request, which must be made on the form of the Purchase Order of the semi-trailer.



Note:

When they do not come installed by the factory, their installation should be performed in one of the RANDONs Authorized outlets, which are duly prepared for the task.

ABS Brake System

RANDON semi-trailers can be equipped with ABS Brake System, which provides greater safety, reliability and durability to the brake components.



Note:

Randon recommends, for better maneuverability, using the equipment fitted with ABS brake when the tractor-truck is also fitted with ABS brake system.

Adjustment of the Brakes:

The semi-trailers equipped with the ABS Brake System, without automatic slack adjuster, must have their brakes adjusted every 2,000 km.

Periodical Maintenance:

Any maintenance in this system shall only be carried out in one of RANDON Authorized Service outlets, thus assuring the quality of the components and their effective performance.



Important:

- When the tractor truck is equipped with ABS brake system, eventual problems in the semi-trailer brake system can be identified by the driver through a specific lamp installed at the tractor truck instrument panel;
- Eventual problems in the ABS system do not disable the regular brake system.

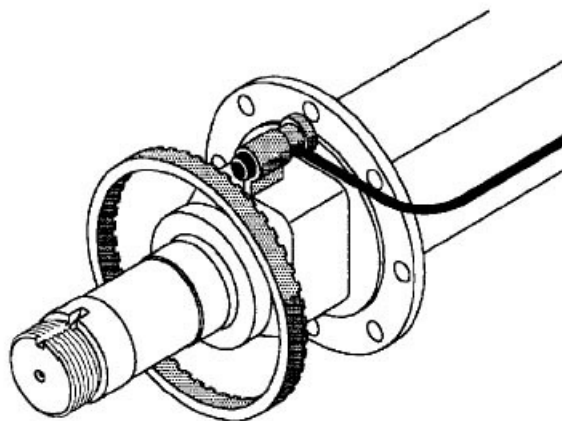

Automatic Slack Adjuster

The automatic slack adjuster is a component that adjusts automatically the brake as brake linings wear, thus keeping the slack between the lining

and the brake drum always constant.

Initial Adjustment of the Brake

The initial adjustment of the brake is necessary only when the brake linings are replaced, after which the brake will adjust automatically.

Use a screw to remove the slack adjuster ratchet. From this moment, the automatic slack adjuster will operate as if it were a manual slack adjuster.

Turn the manual adjustment nut until the linings touch the brake drum, then perform a 5/8 turn with the adjustment nut. Remove the screw and perform in the same way in all other slack adjusters of the semi-trailer.

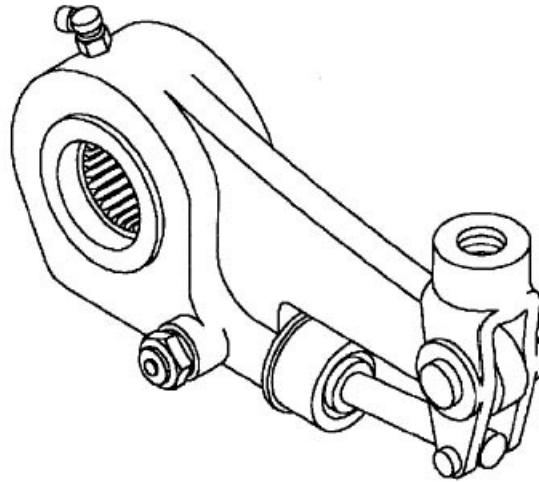

Maintenance of the Automatic Slack Adjuster

At Severe Conditions:

- Disassemble the slack adjuster completely every 100000 km or every year, whichever occurs first.

At Normal Conditions:

- Disassemble the slack adjuster completely every 150000 km or every one year and a half, whichever occurs first.



Important:

- The ideal utilization of the automatic slack adjuster requires its utilization in both the semi-trailer and the tractor-truck;

Food Box

The food box is made of steel sheet, is completely isolated against water infiltration, that is guaranteed for center door lock and two side latches, due to its length.

Below there are some recommendations:

- Load capacity: 60 KG;
- To better tightness, clean the seals every week.



Torque:

- Bolt: M12: 8 à 8,5 Kgfm;
- Bolt: M10: 5 à 5,5 Kgfm.

Tool Box

The tool box is made of polypropylene injected polymer completely water isolated against water isolation, that is guaranteed for center door lock.

Below there are some recommendations:

- Load capacity: 60 KG;
- To better tightness, clean the seals every week.



Torque:

- Bolt: M12: 8 à 8,5 Kgfm;
- Bolt: M10: 5 à 5,5 Kgfm.

TIRES

The safety and performance of trailers/ semi-trailers depend considerably on the condition of the tires. The main purpose of the tire is to withstand loads, provide driving force, adherence to the ground and comfort, and respond to braking actions and accelerations, in addition to ensuring the dirigibility of the vehicle. Each tire is developed within characteristics aimed at withstanding the work it is designed for.



Important:

Lack of maintenance and care associated with irregular maneuvers result in irreversible consequences to the tire, compromising the tread, the bead and the carcass of the tire, showing that the tire has been badly operated.

Warranty



Attention:

For tires purchased along with the trailer, RANDON transfers to its customers the same warranty conditions it receives from its suppliers, that is 3 month from the customer billing date. Therefore, warranty claims must be submitted through the tire supplier's authorized network.

For spare tires sold by Randon, the warranty term is 1 (one) year, according to warranty conditions received from the supplier. Warranty claims, in this case, must be submitted to Randon's Authorized Network.

The warranty conditions of the tire are restricted to manufacturing defects.

Maintenance and Care

For better performance, longer lifespan of the tire, and improved driveability of the semi-trailer, please follow all recommended cares and maintenance procedures, as they avoid premature deterioration and wear of the tire, accidents with property damages and personal injuries, and loss of warranty.

- On poor-condition paved roads, please drive carefully and safely to avoid damages and impacts that may jeopardize the wheel rim and the tire;
- When tires wear from regular use, replace the tire when the point of wear reaches the TWI - Tread Wear Indicator -;
- Use pressure according to the cargo to be transported, as indicated on the tire or by the manufacturer, keeping them calibrated on a daily basis and before long trips.



Comment:

Do not drive with tires below or above the specified pressure. An underinflated tire generates excessive heat, causing deterioration of the tire body and possibly its destruction. Overinflated tires contribute to a variety of problems including increased vehicle vibration, tire wear, and occurrence of punctures.

- Careful Driving : the more abrasive and poorer the road surface is, the shorter will be the life of the tire. Therefore, to increase the durability of the tires it is very important that you drive according to speeds compatible with the type of road, avoiding abrupt braking actions and accelerations. Maneuvers must be performed according to procedures indicated in this manual.
- Alignment and Balancing: proper alignment and balancing must be carried out periodically and whenever you perform preventive maintenance procedures on the suspension, axles and wheels;

- Rotation of tires is recommended to promote more uniform wear for all the tires of a vehicle;
- Periodical inspections are necessary to control wear and eliminate foreign objects picked up on the tire tread or pressed between double wheels, as they can cause irreparable damages to the tires.
- Overloading: avoid overloading, as they cause damages to all components of the tire;
- Storage, move the tires correctly and be careful not to drop them, as the tread can be damaged;
- Mounting of the tire: avoid mounting the tires when they are heated. Twin and uneven tires result in uneven distribution of load on the tires, causing irregular wear.

Maneuvering Hints

- The efforts made by the tire carcass during maneuvers can cause chippings at the bead area, although it is likewise common the burst of the tire rubber and plies displacement;
- It is possible to reduce these effects by using wide turning radius during maneuvers;
- Maneuvering while the tires are heated worsens the problem;
- Performing maneuvers on railways, pavements with spikes, cobblestone pavements, etc. can cause punctures or tears on the tires.



Note:

TWI- Tread Wear Indicator

CONTRAN DIRECTIVE NO. 558/80

Art. 4th-Running vehicles with tires that have reached the TWI – Tread Wear Indicator, or whose remaining tread is lower than 1.6 mm, is prohibited.

Type of Grease

The grease recommended for utilization in all lubrication points of RANDON equipment is of “Multiple Applications” type, lithium-soap based, with EP (extreme pressure) characteristics.

Characteristics:

Base: lithium soap;

Degree: NLGI:2

Drop point: approximately 198°C

Basic Oil: mineral from 138 cSt to 40°C viscosity.

Recommend Brand:

RANDON EP2 - P/N: 1801.00069.

Amount:

- 1,50 kg (one kilo and a half) of grease per wheel hub.
- In further points, an amount enough to keep the components properly lubricated during the established periods of time.



Note:

- The utilization of non-recommended brands will cause the loss of the warranty in the components subject to lubrication, as well as in consequences thereof;
- It is useless using more grease than the recommended amount in hangers (bearings)). Excess of grease will cause overheating during operation and internal increase of pressure, in addition to problems in the wheels;
- The installation of pressure stabilizers for tires in the axles of the equipment changes the internal volume of the hub, impairing grease distribution and the lubrication of hangers (bearings)), in addition to damaging the sealing with possible grease loss.



Important:

RANDON warns that the utilization of grease brands and specifications different from the ones recommended by it impairs lubrication efficiency of the set and contaminates the grease already existent.

item	Description
1	King-pin
2	Landing gear
3	Wheel hub
4	Brake adjuster
5	Camshaft S
6	Mechanical suspension lubrication *
7	Distanced mechanical suspension lubrication bars*
8	Self-steering frame *
9	Self-steering axle *
10	Fifth-wheel
11	Automatic coupling *
12	Spherical coupling *
* When the item applied in the product.	

□ **Note:**

RANDON considers that a semi-trailer operates an average of 12,000 km every 30 days. The mileage and periods mentioned in this manual are the maximum allowed by RANDON. This means you can carry out lubrication procedures at shorter intervals.

Periodic Maintenance Plan

Tasks to be performed during the periodic maintenance procedures:

□ **Comment:**

In the interlink semi-trailer, all instructions herein given must be followed in both, front and rear equipment.

Check the warning signs and list of tasks to be performed during periodic maintenance procedures.

Tasks Column

It identifies the tasks according to the family of components.

Preventive Maintenance Column

Carry out the preventive maintenance procedures according to the indicated periods. These procedures must be performed by the customer/user himself.

A = Daily.

B = Weekly

RANDON recommends that you check visually the following items, every day before you take off;

- Fifth-wheel coupling system;
- Operation of the electric and pneumatic systems;
- Tightening of wheel nuts – see torque table;
- Drain the air reservoir;
- Check the pressure of tires, according to the instructions given by the supplier or as indicated on the tire.

Periodic Maintenance Column

Perform the maintenance procedures periodically, always following the intervals indicated and the recommendation of having this task performed at Randon Authorized Dealer Network.

C = Initial: at 30 days or when completing 10,000 km, whichever occurs first;

D = At every 90 days or 30,000 km, whichever occurs first;

E = At every 180 days or 60,000 km, whichever occurs first.

Column label

Preventive (self) = performed by the operator/owner.

Periodic (network) = performed by the distributor/workshop.

Preventive (Network) 1st Time = performed by the distributor/workshop.

Action	Preventive Maintenance	Periodical (Network)	Periodical (Network) 1 st time
Electrical System			
Check the operation of the electrical system lanterns	A		
Check fixation of electrical components	A		
Pneumatic System			
Clean the air filters	C		
Replace air filter and control panel repairs		D	

Purge the air reservoir	A		
Check for leakage in the pneumatic brake system (valves, hoses and fittings)	C*		
Check brake chamber fixing torque		D	
Examine brake chambers: leaks	C*		
Hydraulic System			
Check hydraulic oil level, leaks and fittings	A		
Check mounting torque of hydraulic kit on horse		D	C
Lubricate clamping bearings and joints	C		
Change oil and air filter		D	
Cleaning the tank and changing the entire system oil		F	
Check air hoses, hydraulic hoses, valves and tank (damage and leaks)	A		
Check end stroke valve, pneumatic control and hydraulic cylinder (operation, damage and leakage)	A		
Clean the outside of the cylinder	B		
Check oil "leakage indicator" hole for oil drip	B		
Check oil and air return filter for dirt	B		
Check drive, function and leakage at T.D.F	B		
Accessories			
Check tire pressure	A		
Side Protector			
Visually inspect attachments and servicing of side guard assemblies	C		
Axles and brake enters			
Check the brakes: adjust the adjusters	Automatic - every canvas change Manual - every 2000 km and lining change		
Check brake linings for wear	B		
Wheel nuts tightening	A		
Check axis alignment		D	C
Adjust the shaft bearing adjustment		D	C
 <p>Attention: Attention:</p> <p>Every time you replace the brake linings, or at 40,000 km, remove the wheels and open the wheel hubs to:</p> <ul style="list-style-type: none"> • Check bearings and change the grease: check hubs, drums and re-tighten screws –see torque table; • Replace toothed washers and retainers (required), together (if necessary); • Examine brake components and replace all the brake shoes springs; • Adjust the backlash of the axle bearings; • Check torque of bolts fixing the brake to the beam disc; 			
Check condition of rocker bushing	C	D	
Check integrity of spring support, torque plate and clamps	C	D	
Check clamp torque		D	C
Check Tension Arm Nut Torque		D	C
Check Rocker Bolt Mounting Bolt Nut Support		D	C
Check spring support cylinder retaining bolt nut torque		D	C
Examine spring scrub wear	C	D	

Single Point Suspension			
Check Center Bearing Torque		D	C
Check spring cover torque		D	C
Lubricate points as indicated in this manual (Ex: bearings and spring cover, pins etc.)	B		
Mixed Pneumatic Suspension			
Check air suspension integrity: traction springs, rubber bushings, air springs (balloons), joints and wear plates when applied	B	D	
Pneumatic Suspension			
Check shock absorber nuts torque, front washer alignment nuts, and air spring retaining nuts		D	C
Check air suspension system: air springs, hoses and leakage	C	D	
Examine rubber bushings, wear washers		D	C
Wear Washer Replacement		E	
Air Axle Lift (for mechanical suspension)			
Check for suspension leaks	B		
Check clamp torque		D	C
Suspension cleaning (contact region between the plates and the edges of the bag)		D	
Air Axle Lift (for pneumatic suspension)			
Check for suspension leaks	B		
Visually inspect for cracks in frame assembly (frame replacement in case of cracks)		E	
Check for any deformation or wear on the air spring and / or pivot bolt		E	
Check the torque of the hanger fixings		D	
Fifth-Wheel and King-Pin			
Clear table and king-pin of the semi-trailer and also the upper fifth-wheel base	B		
Lubricate upper fifth-wheel base, locking mechanism and locking jaw	B		
Adjust Fifth Wheel Handlebar Locking Rod	C		
Examine torque-fixing bolts for kingpin, shoes and fifth-wheel cushions. Polymer insert and polymer plates (the last two applicable for CW and CXW)		D*	C
Check fifth-wheel and king-pin components for wear, deformation or cracking	C	D	
Coupling system			
Examine semi-trailer with directional system (self-directional): air suspension, directional system, coupling, joints, and torques		D	C
Examine Spherical Coupler Tip Torque		D	C
Check Spherical Coupler Pin Torque		D	C
Examine clearance and lubricate self-coupling swivel tip	C		
Check the look of the automatic coupler and measure components for wear	B		
Clean and lubricate locking pin housing and auto-shift yoke bushings	B		
Lubricate the pin housing through the automatic coupling grease fitting	C		
Check tightness of auto-shift yoke nut		D*	C
Checking the torque of the self-locking trigger housing bolts		D	C
Replacing Auto Coupler Rubber Cushions		E	
Lubricate the raceway through the grease fittings by moving it until it forms a grease edge between the raceway frame rings	C		
Review Mechanical Spherical Coupling Torques		C	C
Lubricate locking pins with lubricating oil from Mechanical Spherical Coupler	C		C
Clean and lubricate Mechanical Spherical Coupling locking systems	C	D	C

Before coupling, clean tip and ball pin grease, check tip O'ring conditions, lubricate ball pin, and lubricate through Mechanical Ball Coupler tip grease	A	B	
Perform hook cleaning by applying compressed air to the locking pin housing of the Mechanical Spherical Coupler	B		
Check operation of lifting device		D	
Lubricate the lifting device		D	
Self-Steering System			
Examine semi-trailer with directional system (self-directional): air suspension, directional system, coupling, joints, and torques		D	C
Check Centralizing System Springs	C		
Check that system shock absorbers have eye and body damage	C		
Brake system			
Check components that suffer friction and regular wear, such as: brake pads, springs, drums, retainers, etc	C	D*	
Inspect radial and axial clearances on the expander shaft		D	
Lubricate the system in normal application	C*		
Check brake pad wear	B		
Brake system			
Check Integrity and Warp of Toothed Ring		D	
Check for wear and clean toothed ring	At each opening of the wheel hub	D	
Check torque between ABS / Bracket / Crossbar assembly		D	C
Perform ABS system diagnostics		D	
Chassis			
Check chassis level and overall condition and overall welds	C	E	
Check condition of painting		E	
Cargo box			
Check general condition of cargo box and general welds	C	E	
Check condition of painting		E	

Torque Table

The torques indicated in the table below are those recommended by RANDON. Apply them every time you carry out periodic maintenance procedures, always respecting the intervals indicated. Service should be performed at Randon Authorized Network.

Indication	Torque (Kgf.m)
Lubfree Mechanical Suspension	
Screw the balacim M30	100.0 to 150.0
Rocker pin bearing screw	11.0 to 13.0
Tensioner arm bushing bolts M24	70.0 to 80.0
Tensioning arm adjustment clamp screw M16	25.0 to 30.0
Spring Beam Clip on Shoe M22	40.0 to 50.0
Spring washer fixing screw on the suspension bracket M16	13.0 to 17.0
Mechanical Lubrication Suspension	
Spring Beam Clip on Shoe M22	40.0 to 50.0
Tensioner arm bushing bolts M24	70.0 to 80.0
Tensioning arm adjustment clamp screw M16	25.0 to 30.0
Rocker Cylinder Bolt M16	13.0 to 17.0
Cone Pin M14	10.0 to 15.0
Mechanical Suspension Single Point 22T	
Center bearing nut M22	48.0 to 60.0
Spring cover nut M22	48.0 to 60.0
Central spring clip nut M24	62.0 to 77.0
Mechanical Suspension Single Point 26T	
Center bearing nut M24	60.0 to 80.0
Spring cover nut M24	60.0 to 80.0
Center spring clip nut M30	110.0 to 140.0
Low Combined Pneumatic Suspension	
Traction spring locking nut M30	120.0 to 150.0

Draw spring clip nut M24	70.0 to 80.0
Shock Bolt M20	25.0 to 30.0
Air Balloon Fixing Nut M12	4.0 to 5.0
Air Balloon Attachment Nut M18	13.0 to 17.0
Air balloon base fixing nut	17.0 to 22.0
Pneumatic Suspension - PSYS	
Alignment Bracket Screw Nuts M30	135.0 to 160.0
Air Spring Locking Screw M12	4.0 to 5.0
Shock Bolt Nut M22	48.0 to 55.0
Pneumatic Suspension - TAS	
Alignment Front Bracket Screw Nuts M30	135.0 to 145.0
Air Spring Locking Screw M12	3.4 to 4.7
Air Spring Locking Screw M18	3.4 to 4.7
Shock Bolt Nut M22	48.0 to 55.0
Spring clip nut M24	70.0 to 80.0
Plate fixing screw with M12 arm	10.0 to 12.5
Suspension fixing screw with arm	6.0 to 7.0
Suspension fixing screw with holder	13.0 to 15.0
Axis	
Wheel nut M22 - for shaft to disc (cross direction)	65 to 70
Nut nut M20 - for threaded shaft (cross direction)	25.0 to 30.0
Hub cover screw	1.5 to 3.0
Cube / Drum Assembly Mounting Screw - INBORD	18.0 to 23.0
Axis Clamp Group	

Torque on spring clamps M24	70.0 to 75.0
Torque on spring clamps M22	40.0 to 50.0
Brake System	
Brake Chamber Mounting Nut M16	11.0 to 13.0
Brake Expansion Shaft "S" Bracket Screw	15.0 to 17.0
Brake fixing screw with beam disc	22.0 to 27.0
ABS System	
Locking nut on the Holder M8	1.7 to 2.2
Locking nut of the ABS bracket on the crosspiece M10	3.5 to 4.3
Autodirectional System - Frame	
Spring fixing bolts equalized to crosspiece	1.8 to 2.5
Shock Absorber Bolts	35.0 to 37.0
Self-Directional System - Shaft	
Pneumatic locking cylinder screw	3.0 to 4.0
Shock absorber bolt	35.0 to 37.0
Stabilizer Spring Joint Joint Fixing Screws	17.8 to 19.6
Axle tip clamp screw with steering rod	7.3 to 8.0
Brake Chamber Bracket Screw	4.0 to 4.4
Coupling	
King-pin fixing screw 2"	18 to 20
King-pin fixing screw 3.1/2"	26 to 28
Fifth-wheel mounting plate screw	26 to 30
Drawbar fixing nut – fixed drawbar	40 to 50
Clamp nut – air axle lift	26 to 30

Hubdometer fixing nut	1,5
Coupling system nut - Ball hitch	22 to 26
Castellated nut – Ball hitches	40 to 43
Fixing screws of the trigger housing - Towing Hitch	60 to 80
Fixing screws of front plate on coupling guide - Towing Hitch	110 to 150
Coupling - Rala	
Ring fixing bolt and shims	27.0 to 31.0
Pneumatic Axle Lift - Mechanical Suspension	
Plate fixing nut	6.0 to 8.0
Staple nut	28.0 to 32.0
Suspension fixing screw on the chassis	11.0 to 14.0
Pneumatic Axle Lift - PSYS	
Fixing screw on suspension arm M10	5.0 to 6.0
Fixing screw on the M14 suspension bracket	13.0 to 14.0
Pneumatic Axle Lift - TAS	
Fixing screw of the axle lift on the suspension bracket	6.0 to 7.0
Top bracket screw to axle lift on the arm	13.0 to 15.0
Acessories	
Fixing screw in air axle lift	4 to 5
Side Guard: Fixing screw M8	1,8 to 2,1
Side Guard: Fixing screw M10	5 to 6
Side Guard: Fixing screw M16	16 to 19,5

□ **Important:**

For torques not specified in the above table, we refer to the Random Authorized Distributor Network.

□ **Note:**

Periodic Maintenance recommendations and specific torques of load box components can be found in the **Specific Maintenance** chapter.

Axles Alignment

A perfect geometry provides the semi-trailer with better performance, reduced fuel consumption, steadier speeds, less wear on tires and a better stability of the set tractor-truck and semi-trailer.

Randon recommends aligning axles every 30,000 km or whenever the suspension is serviced. In order to check axles alignment and, in case it is necessary to perform it, RANDON recommends doing so in one of the RANDON Authorized Service Outlets, which count on professionals trained by the factory and equipment for this operation.



Comment:

Unaligned axles shall be covered by warranty only if it occurs in the first two months of use, otherwise it will be considered as maintenance.

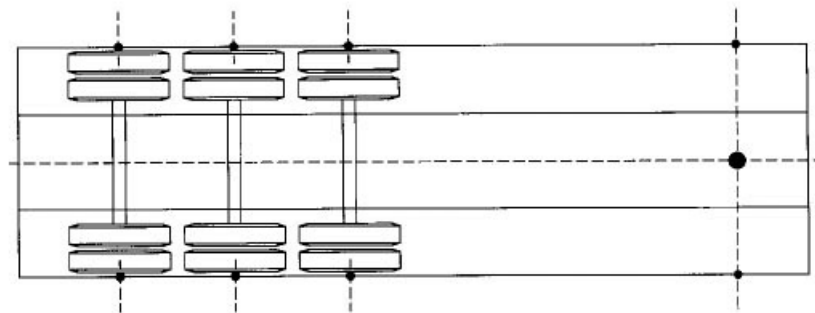

Note:

In the Interlink semi-trailer, all instructions shall be followed in both the front and back-up semi-trailers.

SEMI-TRAILER PAINTING

The painting processes of Randon provide longer durability and better performance no matter what application of the equipment is.

Warranty Period

A Randon attributed paint warranty to or implement specified in this manual to Legal Guarantee of three (03) months and Contractual Guarantee of nine (09) months, totaling twelve (12) months.

Warranty Restrictions on Painting.

For extra protection and longer durability of your equipment painting, RANDON's recommendations must be followed. The validity of the warranty is directly linked to the processes used to preserve the painting of your equipment.



All parts and components that have been damaged by foreign agents, such as: scratches, crashes, blows, damages caused during maintenance (assembly/ disassembly) - with evidence of it – will not be covered by warranty.

RANDON will not warrant painting problems if there is evidence of:

- Washing with improper chemical products, or with products not recommended by Randon, (see semi-trailer cleaning and washing instructions);
- Rocks hitting the trailer and chipping the paint, scratches in the paint, collisions or damages caused during the semi-trailer operation;
- Areas of intense abrasion, such as loading and unloading areas, floors, hinges (sides and turning areas), fixing elements (screws, handles, nuts and washers), twist locks, fifth-wheel upper base and side panel coupling;
- Direct contact with chemical products such as spilling of acids, contact with caustic soda, solvents, paints, sodium hydroxide-base solvents, alkaline products and corrosive materials.
- Fittings in the semi-trailer such as welding and holes to install accessories and others;
- Regular wear and tear of the semi-trailer and parts;
- Utilization of paint not recommended by RANDON.
- Exposure to extreme temperatures;
- Repair/ Service not performed at RANDON Authorized Network.

Semi-Trailer Cleaning and Washing Instructions

In order to prolong the painting durability and keep its good appearance, RANDON recommends that you carry out maintenance on a regular basis.

Carefully read the recommended instructions whenever you clean or wash your equipment.



Important:

Protect the environment. Always use cleaning products that do not harm the environment.



Attention:

RANDON recommends that you use products with neutral ph when cleaning your equipment (from 5 to 7.5).



Use cleaning products that are proper for washing.

Never use any alkaline or acid products, as they are extremely harmful to painting.

High-Pressure Cleaning Device/Equipment

Avoid using high-pressure to clean components such as valves, gaskets, seals, etc...

Do not apply jets directly on the part to avoid ingress of water, which may cause damages.

Anti-Corrosive Protection

Anti-corrosive products must be added to provide effective protection to your equipment.

RANDON recommends that you use water-based anti-corrosive products, preferably of the brand **Tirroil 957 D/60**.

Painting Re-Touching

Randon recommends that you repair painting damages as soon as you detect them. The earlier repairs are made, the lesser the risk of corrosion.

To repair painting or eventual damages such as chipping caused by stones/rocks, scratches and others, visit an Authorized RANDON Dealer.

EQUIPMENT CHARACTERISTICS

Silo Tank Semi-trailer

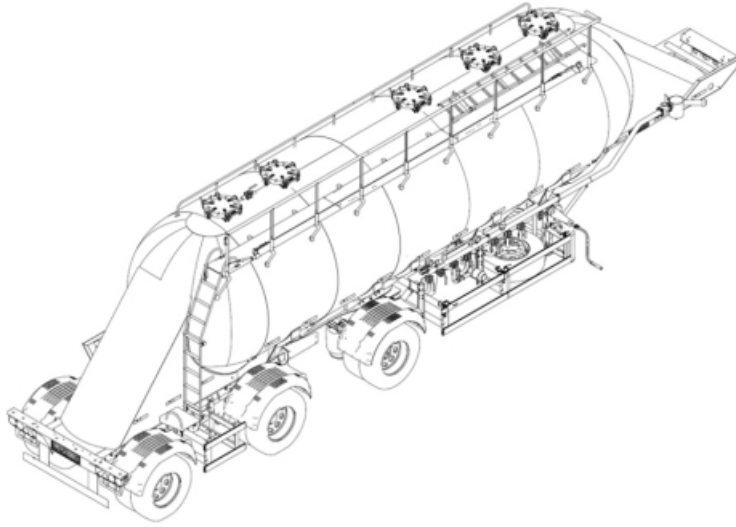

Silo Tank Interlink Semi-trailer

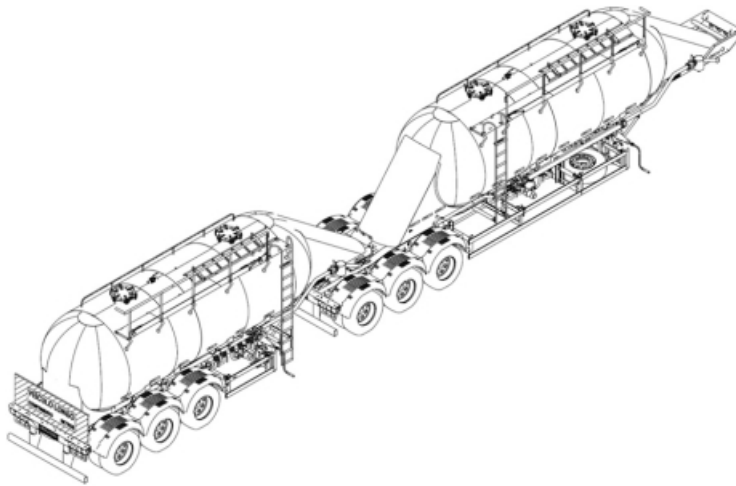

V-Silo Tank Semi-trailer

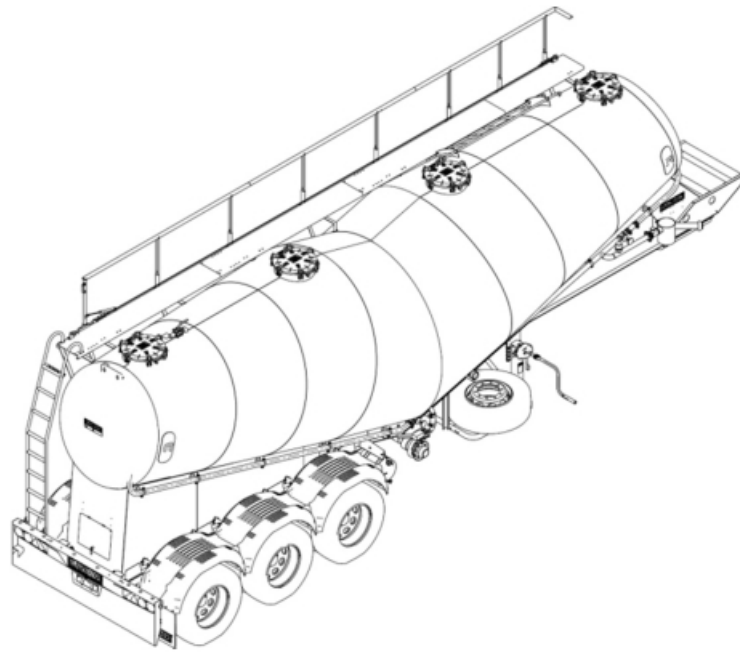

Loading System

The silo equipment is designed to transport dry bulk pulverized products that can be discharged with controlled pressure. The equipment should never travel with a pressurized load body.

Randon offers two load body models: The cylindrical model and the V shaped model. For both models the loading and unloading procedures are the same.

It has a 03" connection of adapt the compressed air entry hose and a 04" connection to adapt the unloading hose.

The discharge valves are activated by a pneumatic system that uses rotating control valves.

The Randon semi-trailer has a loading, unloading, and maintenance operation instruction label attached to the side near the discharge operation valves.



Comment:

The maximum allowed working temperature for silos is 70°C.

Loading

Instructions for loading operations.

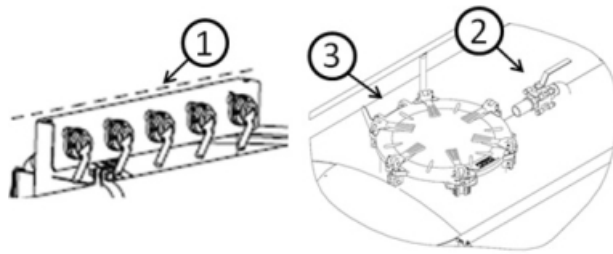

- Place the equipment in the correct cargo location;
- Activate the parking break;
- Make sure the rotating valves (ind. 1) are closed;
- Open the relief valve (ind. 2) on the upper portion of the silo to equalize the load body and atmospheric pressure;
- Open the manholes (ind. 3) as stated in **Opening the Manhole**;
- Check for any residue or humidity inside the load body or in the discharge system;



Attention:

Do not load if the silo has moisture or humidity inside or in the piping, and/or if the cargo is not in the appropriate loading conditions.

- Load according to chapter **Cargo Distribution**;
- After finishing loading, clean off any residue that might remain on the manholes and the sealing rings;
- Close the manholes (ind. 3), according the chapter **Close the Manhole**, keeping the same closing pressure on all the cranks and close the relief valve (ind. 2) so that the load body is hermetically sealed.

Opening the Manhole

Recommended procedure for opening the manholes. On the manhole, the manufacturer recommends some precautions when opening and closing the manhole.

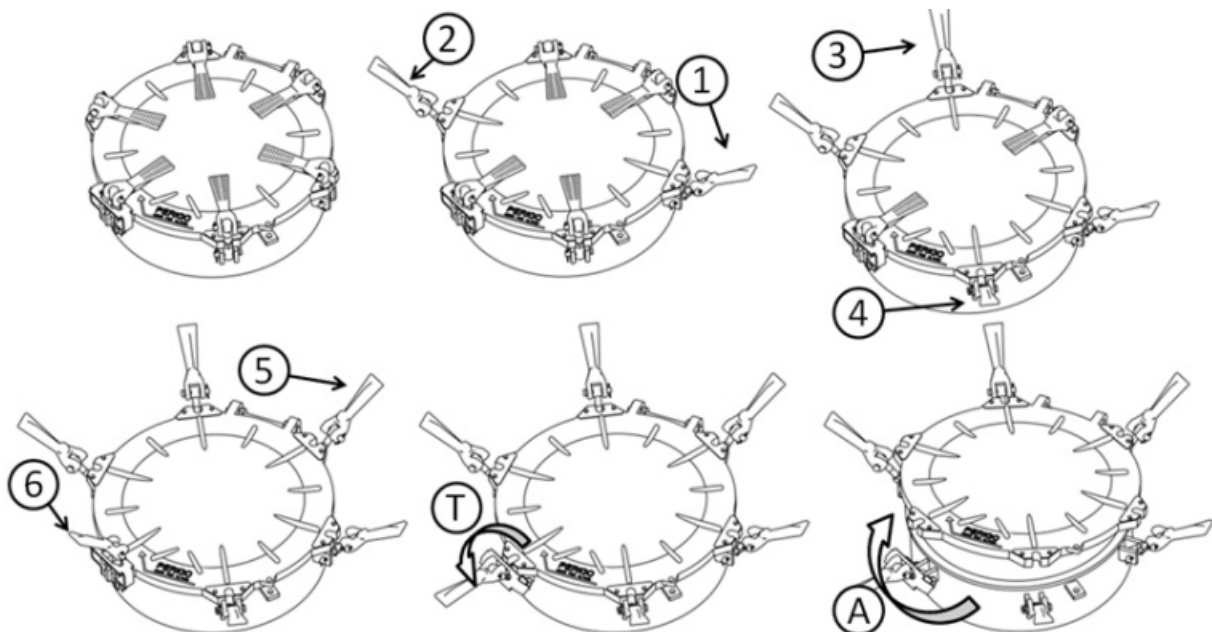

- Open the cranks (ind. 1) and (ind. 2) then the cranks (ind. 3) and (ind. 4) finally the cranks (ind. 5) and (ind. 6);
- Turn the safety lock (ind. T) of the crank (ind. 6);
- Open the manhole (ind. A).



Attention:

The safety lock (ind. T) keeps the manhole from opening abruptly if the silo was not fully depressurized.

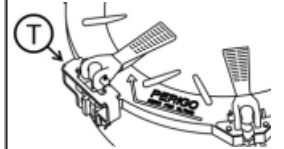

Close the Manhole

To close the inspection cover, follow the procedure below. Be sure to adjust the crank spindle so everyone applies the same pressure on the manhole.

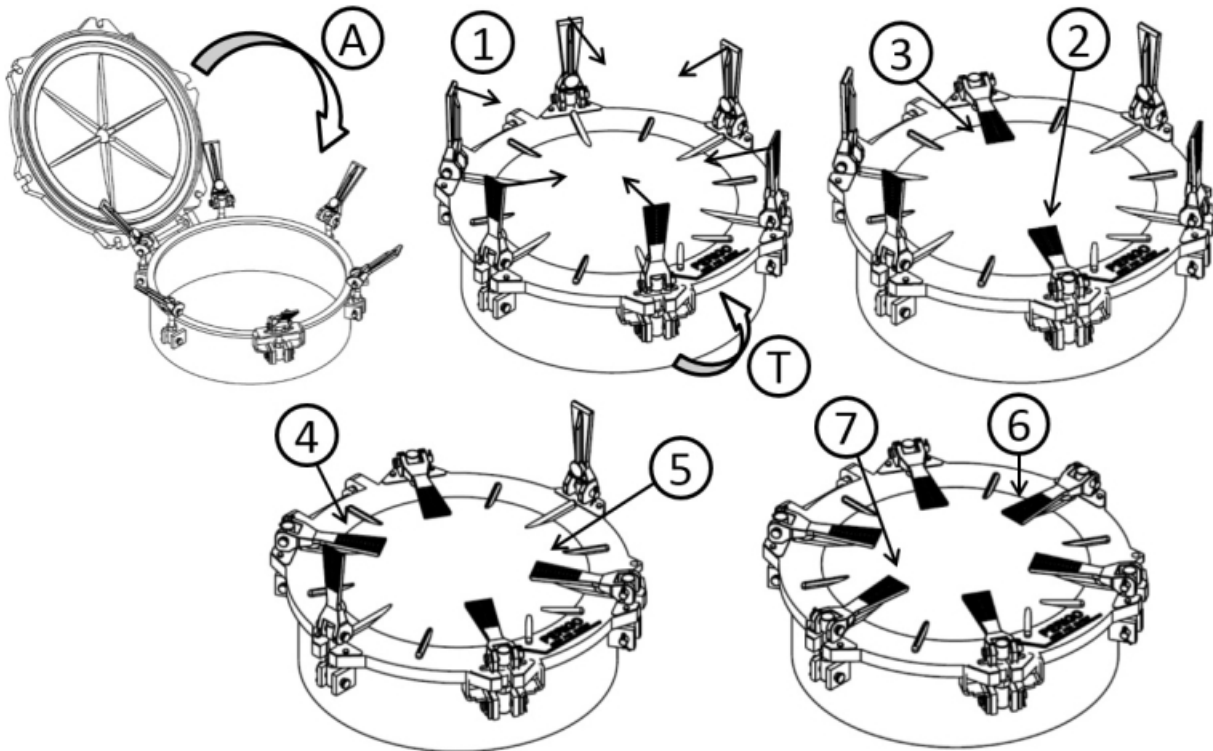

- Before closing the cover, make sure that the sealing rubber is properly seated. Carefully close the inspection manhole (ind. A), making sure it is seated properly on the ring.



Note:

Check the integrity of the manhole rubber. It should not be cut, crushed or have cracks that allow the loss of pressure in the body of the Silo.

- Turn the safety lock (ind T) of the crank;
- Approach all crank (ind. 1), make sure they are adjusted (see the Crank Adjustment chapter);
- Manually close the crank, always in pairs in the sequence (ind. 2 - 3, 4 - 5, 6 - 7).

Crank Adjustment

Based on the figure below, complete the following procedure:

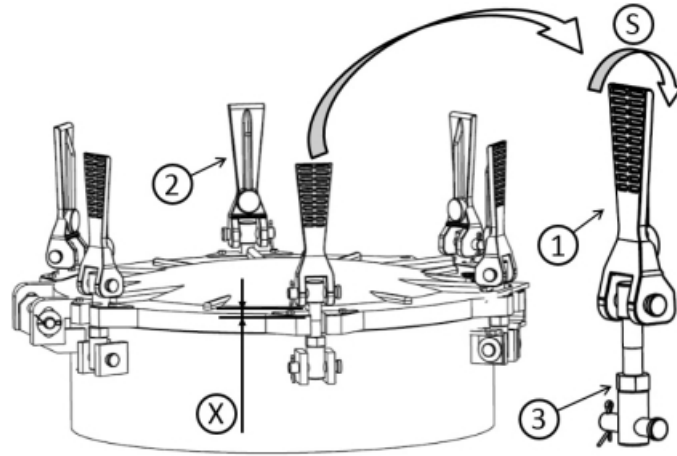

- Keep all cranks open, resting on the lid;
- Loosen the locking nuts (ind. 3) of the cranks (ind. 1 and 2). The initial regulation must be effected initially between two cranks located in opposite positions between them, to guarantee the equivalent settlement to both sides of the manhole;
- Pressure regulation is performed by turning the handles (ind. 1 and 2) in the direction (ind. S) clockwise (to increase the pressure of the cover on the ring) or anticlockwise (to decrease the pressure of the cover on the ring);
- To facilitate adjustment, it is recommended to maintain the same distance (ind. X) between the crank and the manhole;
- Close the cranks simultaneously (ind. 1 and 2) and check that the pressure exerted on them is adequate. If it is not, open and rotate the cranks in the direction (ind. S) of the hour or the left, as necessary. Repeat this procedure until pressure is adequate;
- Perform the same operation described above for the other cranks, always in opposite pairs;
- Close the nuts (ind. 3);



Note:

All opening, closing and regulating processes must be performed manually. Do not use tools such as hammer, bars and etc. The use of tools damages the manhole and can cause unwanted accidents in the operation of Silo.



Important:

The adjustment of the crank must be carried out by a trained professional. Consult a Randon Authorized Service Center for the perfect adjustment of the system.

Unloading

For the cylindrical silo, Randon offers two discharge models for the unloading of the transported material: The cushion system and the fluidizer system. For the V-Silo, the discharge system is like the cushion system.



Attention:

The unloading procedure for both discharge system models is the same. The difference is the source of compressed air. The cushion discharge system uses a compressor, but the fluidizer system uses a blower.

The operator should not step away during the unloading process, especially when the load body is pressurized. In case of emergency, it is possible to depressurize the load body using the emergency valve (ind. 11).

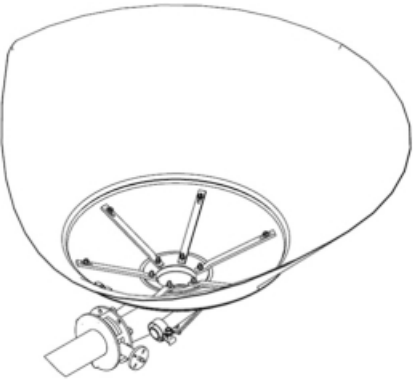
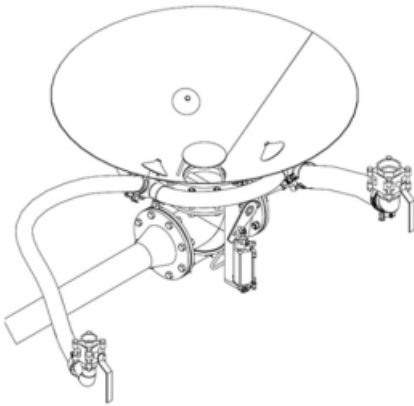
Cushion	Fluidizer
	

Instructions for Unloading Operations

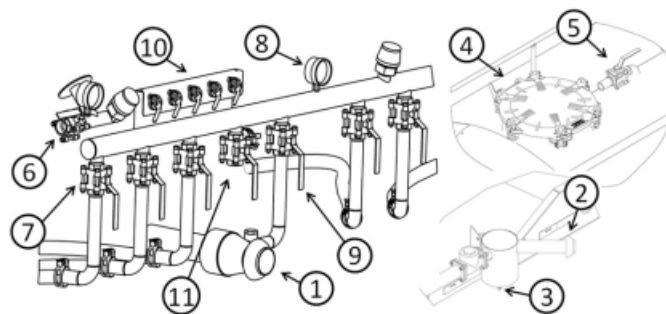

- Place the equipment in an appropriate cargo location;
- Activate the parking break;
- Connect the 04” unloading hose to the unloading connection (ind. 1) until reaching the stationary silo that will receive the load;
- Connect the 03” air hose between the air source (compressor or blower, depending on the discharge model) to the entry connection (ind. 2) of the equipment’s air distribution piping;
- Drain the condensed humidity from the dehumidifier, using the bleeder (ind. 3) located on the bottom of the dehumidifier;
- Pressurize the tank according to the following instructions.



Attention:

A Randon recomenda executar as tarefas, principalmente as de pressurização e descarga, com a máxima atenção, cuidado e segurança, para evitar qualquer tipo de acidente ou dano.



Note:

A pressão de trabalho pode variar de 1,0 a 2,0 kgf/cm², dependendo das condições de descarga. A pressão máxima interna do silo não pode ultrapassar os **2,0 kgf/cm²**.

Pressurization

After checking and executing the previously described steps, pressurize the equipment in the following manner:

- Make sure the manholes (ind. 4), the relief valve (ind. 5) and the dead space valve (ind. 6) are hermetically sealed;
- Activate the air source, releasing compressed air into the equipment;
- Open the cushion release valves (ind. 7), controlling the working pressure on the manometer (ind. 8);
- Make sure the unloading hose is properly connected and that there are no leaks;
- Close the accelerator valve (ind. 9) and wait until it reaches the working pressure.

Unloading

- Open the unloading accelerator valve (ind. 9) all the way, as needed;
- Slowly and completely open the rotating valve (ind. 10) for the cushion that will be unloaded;
- Adjust the opening of the unloading accelerator valve (ind. 9) in such a way as to maintain the working pressure of the manometer (ind. 8);
- When the pressure reaches levels below 0.5 kgf/cm² the cushion will be empty;
- Close the rotating valve (ind. 10) completely for the unloaded cushion and then partially close the release valve (ind. 7) for the unloaded cushion.



Note:

- Randon recommends unloading one cushion at a time;
- During unloading, only open the release valve (ind. 7) for the cushion that will be unloaded;
- To maintain the work pressure of the manometer (ind. 8) partially close the accelerator valve (ind. 9) making sure the material that is unloading does not obstruct the piping;
- Randon does not recommend hitting the sides of the tank or the piping with rubber mallets or the like in order to help unload the material.



Comment:

To unload the remaining cushions, repeat the same operations mentioned previously.

Completing the Unloading

After completing the last unloading, proceed as follows:

- Open all rotating valves (ind. **10**) and all of the release valves (ind. **7**) for all the cushions;
- Also open the accelerator valve (ind. **9**);
- Maintain the source of air running for about 10 minutes to clean out the system;
- Turn off the compressed air source and wait for the system pressure to reach ZERO on the manometer (ind. **8**);
- Make sure the unloading process is complete, making sure there is no residue inside the load body;
- Decouple and put away the Ø3" hose (ind. **2**) and Ø4 hose (ind. **1**);
- Close all of the valves of the unloading system;
- Make sure the manometer (ind. **8**) pressure is zero. If any pressure remains, open the relief valve (ind. **5**) on the upper part of the silo;
- Replace the closures of the discharge outlet (ind. **1**) and the air intake (ind. **2**);
- Close the relief valve (ind. **5**).

Cargo Distribution

The cargo distribution in the semi-trailer should comply with the Scale Law. Also, excess or poorly distributed cargo can cause serious damage to the equipment.

When loading, Randon recommends the following guidelines for:

1. **Volume:** the cargo volume should be equal or less than the load body's;
2. **Total Weight:** the cargo weight should be equal or less than the recommended net cargo capacity listed on the equipment's identification plaque;
3. **Capacity per Axle:** beside total gross weight, the cargo capacity per axle should not surpass the maximum allowed by current law.



Note:

To comply with the regulations of the law, it is important to check volume, weight, and properly distribute the cargo.

Loading and Unloading Technical Data

To guide the calculations and demonstrate the performance of the equipment, the table below shows comparative values, such as: minimum air flow, unloading flows, stationary silo height and working pressure, considering the most commonly transported products transported and their respective specific weights.

The values are basic, and may vary depending of the capacity of the air compressor, the condition of the facilities, and the characteristics of the transported product.

Transported Product	Specific Weight Kg/m ³	Minimum Air Flow m ³ /min	UNLOADING FLOW ACCORDING TO PRESSURE (Unit Tons/Hour)								
			Silo Height Stationary 10.00m			Silo Height Stationary 20.00m			Silo Height Stationary 30.00m		
			Pressure 1.0 bar	Pressure 1.5bar	Pressure 2.0bar	Pressure 1.0bar	Pressure 1.5bar	Pressure 2.0bar	Pressure 1.0bar	Pressure 1.5bar	Pressure 2.0bar
Aluminum	920	9,6	21,6	36	50,4	20	33	45	18,7	30,2	41,4
Bauxite	800	5,1	34,5	54	77,4	28,8	46,8	66,6	24,1	39,6	57,6
Bentonite	750	4,5	48,6	77,4	-	43,2	66,6	-	37,8	59,4	66,6
Limestone Powder	800	6,2	28,4	45,6	68,4	23,4	36	54	18,3	29	41
Limestone Pulverized	1000	7	36	54	75,6	-	45	66,6	-	36	55,8
Cement	1150	4,5	33,5	55,8	81	28,8	50,4	72	25,5	43,2	66,6
Fish Meal	535	5,8	18	24,8	30,9	-	-	-	-	-	-
Fish Meal	500 - 600	5,8	30,9	46,8	-	25,2	41,4	-	22,3	36	-
Magnesium Oxide	420	5,8	33	46,8	61,2	27,3	39,6	54	23,7	36	48,6
PVC - Granulated	750	10,7	9	14,4	18	7,9	12,6	15,8	6,8	11,1	13,6

Technical Data

	Free fall unloading		Pneumatic unloading	
Hose diameter	Necessary air volume	Necessary pressure	Necessary air volume	Necessary pressure
80mm (ø3")	-	-	5,5 a 6,0m ³ /min	-
100mm (ø4")	16,0 m ³ /min	0,5 kgf/cm ²	9,0 a 10,0m ³ /min	2 kgf/cm ²
130mm (ø5")	-	-	15,0 a 16,0m ³ /min	-

Loading and Unloading Dimensions

H1 - Height of the Silo Tank Semi-trailer: 3,750mm

H2 - Maximum consolidation height: 48,000mm

R - Minimum radius for the piping curve: 2,000mm

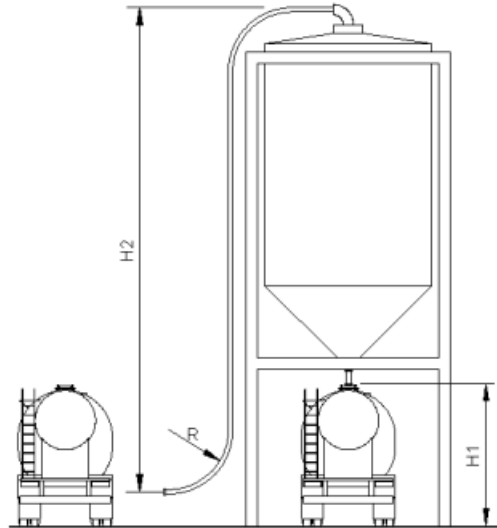

Load Body

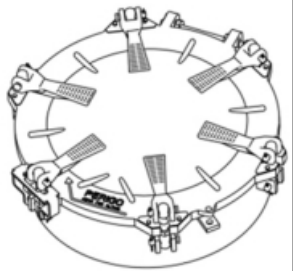
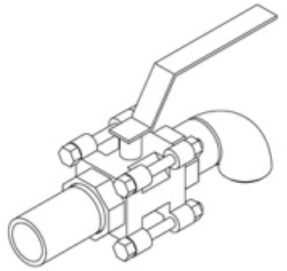
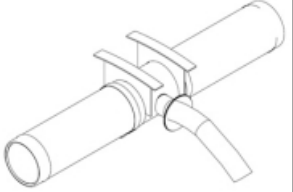
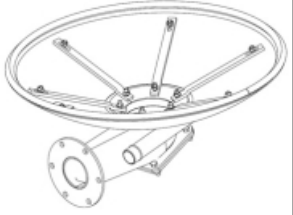
<ul style="list-style-type: none">• Manhole <p>The manhole is located in the upper portion of the load body, in the center of the silo.</p>	
<ul style="list-style-type: none">• Relief Valve <p>The relief valve is located on the upper part of the silo, near the rear hubcap.</p>	
<ul style="list-style-type: none">• Dead Space Filter <p>Located inside the load body, it filters through an air cloth that equalizes the pressure in the dead space.</p>	
<ul style="list-style-type: none">• Unloading Cushion <p>Located in the bottom of the equipment, it is the component responsible for unloading the silo with this type of discharge model. The load body is pressurized using this component.</p>	

Screen Assembly in the Air Cushions

To replace the nylon fabric (screens) of the air cushions, follow the instructions below:

- Clean the outer ring (ind. 1) and the inner ring (ind. 2), removing all the old glue;
- Place the perforated plate in a funnel shape (ind. 3) adjust it with the aid of the fastening ring (ind. 4), removing the ring after adjustment;
- Use “Araldite” type glue (ind. 5) on the outer ring (ind. 1);

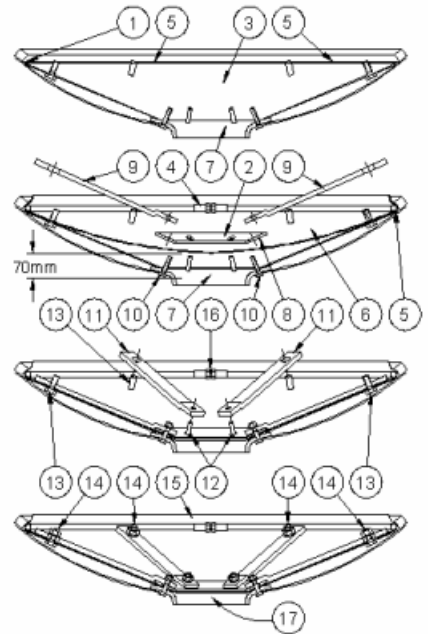

- Place the fabric - screen (ind. 6) so that it remains about 70 mm from the bottom ring (ind. 7);
- Place the central fastening ring (ind. 2) on the screen, but first apply the “Araldite” type glue (ind. 8) between the rings. Assemble the two fastening bars - one on each side (ind. 9) to the bolts (ind. 10) and tighten until the central fastening ring (ind. 2) touches the bottom;
- Assemble the four other fastening bars (ind. 11) tightening the bolts as necessary (ind. 12);
- Find the bolt holes (ind. 13) of the perforated plate (ind. 3) located below the screen. Use a pencil to not damage the fabric (ind. 6);
- Carefully open the holes in the fabric - screen (ind. 3). Use a round and hot iron of approximately 8mm of diameter;
- Assemble the six nuts (ind. 14) interspersed, tightening when necessary;
- Open the larger central hole in the screen (ind. 17) and cut out the remains (ind. 15) next to the fastening ring (ind. 4) leaving about 20 mm leftover. Use a hot iron to seal the nylon edge.



Attention:

The silo will only be ready for use after the glue has dried in the assembly of the external ring (ind. 1) and the inner ring (ind. 2) i.e., for approximately 24 hours after applying the glue. It can vary, depending on the type of glue used.





Note:



For any internal inspection or maintenance of the load body, use the internal access ladder, for the operator's safety.

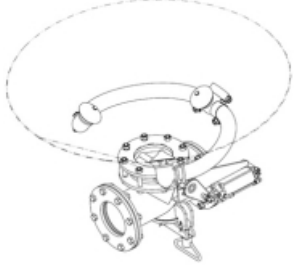
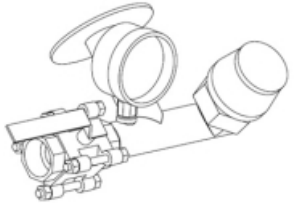
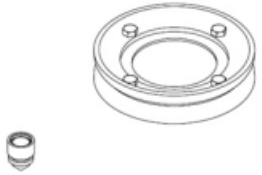
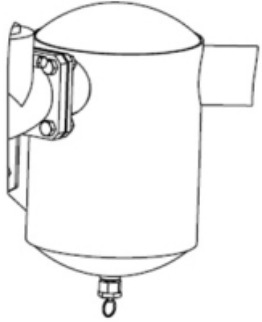

Attention:

The filters are necessary to maintain the balance of the pressure between the inside of the load body and the dead spaces, as well as providing speed during unloading. These filters should be kept clean, unobstructed, and free of any tears to avoid damage to the cones.

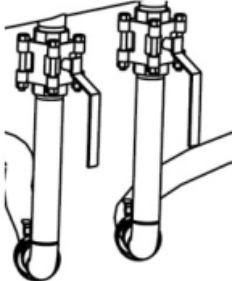
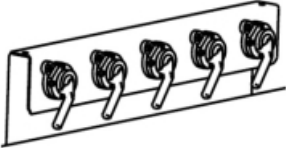
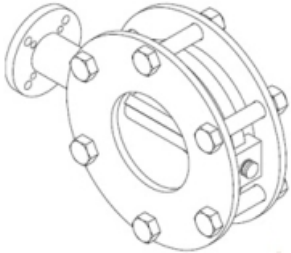
<ul style="list-style-type: none">• Fluidizer <p>Located in the bottom of the equipment, it is the component responsible for unloading the silo with this type of discharge model. The load body is pressurized using this component.</p>	
<ul style="list-style-type: none">• Dead Space Equipment <p>Located near the rotating valves, this set includes the manometer, the safety valve, and the spherical valve. It is fastened next to the dead space and serves to verify its internal pressure.</p>	
<ul style="list-style-type: none">• Dead Space Cleaning Flange <p>Located in the bottom part of the silo, it's purpose is to inspect and clean the dead space.</p> <p>If there is and residue from transported cargo, check the hose and the dead space filter cloths.</p>	
<ul style="list-style-type: none">• Condenser <p>Located on the air distribution tube near the rotating valves, it is to register the internal pressure of the equipment.</p>	
<ul style="list-style-type: none">• Manometer <p>Located on the air distribution tube near the rotating valves, it is to register the internal pressure of the equipment.</p>	

<ul style="list-style-type: none"> • Safety Valve <p>Located near the manometer. To be activated if the internal pressure surpasses 2.2 kgf/cm² in order to stabilize the pressure.</p> <p>Valve tests must be done at least every 12 months, and can be more frequent, even monthly, depending on the type of material being transported. The valve should be inspected and retested when the equipment is out of operation for a period longer than six months, as well as after maintenance.</p>	
<ul style="list-style-type: none"> • Discharge Valve <p>Spherical valves located below the rotating valves. They are used to pressurize the load body.</p>	
<ul style="list-style-type: none"> • Rotating Valve <p>Located on the air distribution tube near the discharge outlet. They are used to activate the discharge butterfly valve.</p>	
<ul style="list-style-type: none"> • Butterfly Valve <p>Located on the outlet of each cushion. It is used to release the discharge of the transported product.</p>	
<ul style="list-style-type: none"> • Internal Access Ladder <p>Located next to the catwalk on the upper part of the silo. It is used to access the internal part of the silo.</p>	



Attention:

In case of an accident, regardless of the extent of the damage, the silo should be removed immediately from circulation and completely inspected before returning to operation. Randon recommends doing the hydrostatic test to release the equipment.

**Note:**

Over time, the components of the Silo undergo wear for the friction with the transported material, both in the load body and the piping. Since it is equipment subject to high internal pressure, for safety reasons, Randon recommends that after a year of use, measurement of widths and resistance for components that undergo pressurization be tested, checking the maintenance and safety conditions.

SILO MAINTENANCE

Randon recommends following the maintenance instructions below to increase the useful life of the product's load body components, extending the useful life of the structural components.

Preventive Maintenance Column

Carry out preventative maintenance according to the recommended periods. These should be done directly by the customer.

A = Daily.

B = Weekly.

Periodic Maintenance Column

Carry out maintenance in a periodic fashion, following the recommended intervals and services executed at the Authorized Randon Network.

C = Initial 30 days or 10,000 km, whichever comes first.

D = Every 90 days or 30,000 km, whichever comes first.

E = Every 180 days or 60,000 km, whichever comes first.

Maintenance Tasks	Preventive Maintenance	Periodic Preventive Maintenance
Make sure the relief valves and manometers are not obstructed		C
Check the discharge system: Filters, air cushions, hoses and equipment	B	E
Check if there are leaks in all the valves of the discharge system		C,D
Check the wear of the Fluidizer disc		E
Check for accumulated material inside the Fluidizer disc		D
Check for wear of the rubber protector, next to the Fluidizer		E
Inspect the internal and external parts of the silo body		E
Do a general cleaning of the piping, components, and tank interior.		D



Attention:

If the tubes, hoses, sealing components and piping joints, sealing components and valve joints are damaged, replace them immediately.

**Attention:**

For safety reasons, Randon recommends that the equipment must be operated by experienced professionals who are familiar with the safety conditions, use, and maintenance of the equipment.

**Attention:**

The useful life of the manhole is estimated in 6 years. After this period of time, Randon recommends replacing the manhole since it is a part that undergoes wear.

Tabela de Torques

Follow the torque instructions below recommended by RANDON. Carry out maintenance in a periodic fashion, following the recommended intervals and services executed at the Authorized Randon Network.

Recommended Torque	Torque (Kgf.m)
Bolt on attachment bed of load body - Tanks	21 to 26 kgf.m

IDENTIFICATION PLATE THE TANK

It informs the characteristics of the tank: data of manufacture, type of tests and carried product.

Content:

PRODUCT:	numbers that identify the products to be carried in agreement INMETRO;
Nº PRODUCTION:	number of production of the tank;
NORM FABR.:	regulation technician the one that if destines the carried product;
DATES FABR.:	date of manufacture of the tank;
ORIGINAL TARE:	weight of implement it complete without load;
CAP. GEOMET.:	total volume of the container, Express in liters;
MATERIAL:	material used in the confection of the tank;
ESP. MIN. PROJECT:	minimum thickness of the plate recommended under norms;
ESP. CALOTAS:	used real thickness;
ESP. BACK:	used real thickness;
PRES. PROJECT:	pressure used for the project;
PRES. TEST:	the most raised pressure that the tank was submitted;
PRES. OPERATION:	maximum pressure of work of the tank;
TEMP. OPERATION	maximum temperature of work of the tank.

RANDON		INDUSTRIA BRASILEIRA	
PRODUTO	<input type="text"/>	ESP. MIN. PROJETO	<input type="text"/> mm
Nº. PRODUÇÃO	<input type="text"/>	ESP. CALOTAS	<input type="text"/> mm
NORMA FABR.	<input type="text"/>	ESP. COSTADO	<input type="text"/> mm
DATA FABR.	<input type="text"/> / <input type="text"/> / <input type="text"/>	PRES. PROJETO	<input type="text"/> / <input type="text"/> / <input type="text"/> KPa
TARA ORIGINAL	<input type="text"/> Ton	PRES. TESTE	<input type="text"/> KPa
CAP. VOLUMET.	<input type="text"/> m³	PRES. OPERAÇÃO	<input type="text"/> KPa
MATERIAL	<input type="text"/>	TEMP. OPERAÇÃO	<input type="text"/> °C



Note:

On the case of the interlink tank, plate of identification of the tank is affixed on the equipments front and back, identifying each one individually.

INMETRO Identification Plate

INMETRO Identification Plate arranged by Official Office, whose qualify the Tank use.

INMETRO number, vehicle plate, capacity and compartments number of Tank are recorded on it.

	PLACA DE IDENTIFICACAO	Nº. INMETRO
		<input type="text"/>
	Nº. DE COMPARTIMENTOS	PLACA DO VEICULO
	<input type="text"/>	<input type="text"/>
		CAPACIDADE DO TANQUE
		<input type="text"/>

INMETRO Inspection Plate

INMETRO inspection and capacity verification plate, which qualify the Tank utilization. The plate contents INMETRO number, the sequential number and the next inspection date.

Identify, moreover, the Official Office that did the inspection.

	Nº. INMETRO	Nº. INSPECAO
	<input type="text"/>	<input type="text"/>
	PROXIMA INSPECAO	
	<input type="text"/>	

INMETRO Capacity Certify

Certify emitted by an Official Office, of obligatory use, that authorize and technically qualify the tank for dangerous products transport, like the groups specify by INMETRO. The tank can't transit loaded without this certify; and has its validity alike the products group transported.

INMETRO Verification Certify

It's a Document emitted by INMETRO, that certify the tank volumetric capacity.

Obligatory use in combustible transporting, and must be presented on load time. Has one year validity.

Observations for Semi-Trailer B Double Tank



Comment:

The identification or Inspection plate by INMETRO is fixed in front and rear Semi-Trailers, identifying both of each individually.

The Certify of Capacitating and Weights Verification by INMETRO are emitted for the front and rear Semi Trailers individually.

INSTRUCTIONS TO THE CUSTOMER

Dear Customer,

The information below should be passed on to you by the technical consultant that makes the equipment's technical delivery. They are to increase your satisfaction and prolong the durability of your equipment, as well as to ensure its full functionality.

Delivery Instructions

<i>Equipment:</i>	<i>Silo Tank Semi-trailer</i>
	<i>V-Silo Tank Semi-trailer</i> <i>Silo Tank Interlink Semi-trailer</i>

Suspension and Structure:

- Lubrication Points: location and regularity;
- Operation of the pneumatic lift;
- Operation of the spare carrier and attachment of spare tire;
- Check for king-pin wear, acceptable measures and regularity;
- Operation with lift device;
- General suspension retightening
- Use of pneumatic suspension, if included.

Brake System

- Check for brake pad wear: regularity and procedures;
- Brake adjustment: regularity and procedures;
- Drainage of the air reservoir: regularity and procedures.

Steering System:

- Basics of functionality, adjustments, and the use of the steering system;
- Points that affect the cargo distribution;
- Periodic maintenance of the steering system.

Load Body

- Loading and unloading processes: pressurization system, fluidification
- Safety System: valves, equipment, pressure, and care;
- Recommendations and instructions about compressors;
- Types of transported products;
- Cargo distribution.

Periodic Maintenance Plan:

- Ideal times to execute the maintenance plan;
- Recommended torque on torque table;

- Importance of periodic maintenance;
- Execution locations.

DELIVERY TECHNICAL INSPECTION

Upon delivery, the equipment should be submitted to an inspection following the list below, executed by a technical consultant from the factory of the RANDON Authorized Network.

Inspection and Delivery Table

<i>Equipment:</i>	Silo Tank Semi-trailer
	Silo Tank Interlink Semi-trailer V-Silo Tank Semi-trailer

Check:

Suspension and Structure:

- Test electrical system;
- Tightening of the clamps for the spring leaves;
- Tightening of the wheel nuts;
- Tightening and attachment of the torque-arms;
- Pneumatic suspension, if included;
- Functionality of the lifting device;
- Attachment of accessories: tool box, spare carrier, water tank, etc.

Brake System

- Brake adjustment and attachment of brake chambers.

Load Body:

- Check cargo: manholes and equipment;
- Check the unloading system: valves and piping;
- Pressurization system, fluidification: filters and air cushions;
- Safety System: valves, manometers, and equipment;
- Test electrical system;
- Check accessories.

Steering System:

- Functionality of the steering system;
- Adjustment of pneumatic suspension;
- Lubrication of the directional system.

General:

- General paint conditions: scratches, etc
- General condition of equipment: dents, etc.

Dear Technician,

After completing the inspection tasks above, the Customer should sign the rear side of the delivery coupon of the Warranty Certificate, initiating its validity.

MISCELLANEOUS

RANDON equipment bear information such as numbers, plates, etc. that help in the identification, instructions and or licensing.

Chassis Number

It is the legal identification of the equipment (VIN). It is located on the chassi right and left sides, close to the landing gear. It is composed of 17 characters, according to the example below:

9ADP12430GM063455



Attention:

Whenever you refer to this equipment, use the chassis no. as reference.

Identification Plate

It contains the basic information of the equipment.

MODEL:	Letters indicating the equipment model;
VIN NUMBER:	Legal identification no. of the equipment (chassis no. - VIN);
PRODUCTION NUMBER:	Serial production number;
VOLUMETRIC CAPACITY:	Volumetric capacity of the equipment in case of tanks and dump semi-trailers;
TARA:	Equipment weight, unloaded;
CAPACITY:	Technical capacity of the equipment
MANUFACTURED YEAR:	Year in which the equipment was manufactured. Ex: 2000
MODEL YEAR:	Year of the model: Ex: 2001
PESO BRUTO TOTAL:	Total capacity (tare plus technical capacity);
MANUFACTUR :	Code of the assembling plant unit of the equipment;
DATE:	Date in which the equipment was delivered to customer by the factory or Assembling Plant Unit.



Note:

In the Interlink semi-trailer, the identification plate is affixed on the front and rear semi-trailers, identifying each one individually.

RANDON

IMPLEMENTOS

208008900

MODEL _____

VIN NUMBER _____

PRODUCTION NUMBER _____ MANUF. YEAR _____

VOLUMETRIC CAPACITY _____ m³ MOD. YEAR _____

TARE _____ Kgf. ASSEMBLED IN _____

LEGAL CAP./TECH. CAP. _____ Kgf. _____

GROSS TRAILER WEIGHT _____ Kgf. DATE ____ / ____ / ____

LEGISLATION

Bumper

To meet Resolution 152, Randon installs the reinforced bumper, which is designed and approved by the competent bodies. In some cases, the products may be exempt from bumpers, as discussed in the next item.

Implements that have reinforced bumpers must have a nameplate containing the manufacturer's name, CNPJ, technical report approval number and name of the institute or body that issued the approval report. Implements transporting hazardous cargo (RTQ) must also have another Inmetro nameplate with Inmetro's logo, serial number, manufacturer's brand, vehicle chassis number and UCI accreditation number.



Comment:

The owner is responsible for the inspection and maintenance of the nameplate, in order to ensure its preservation according to the current legislation of the country.

Exemption of the reinforced bumper on trailers and semi-trailers manufactured by Randon

Since the publication of Ordinance 11/04, products that have a distance between the rear end and the tangent of the last smaller 400 mm tire are exempt from the bumper, but they must carry a metal profile with reflective blade. The length must be at least equal to the distance between the inside faces of the rims or wheels. This bumper has no structural purpose but signaling (support the reflective sticker).



Attention:

This procedure does not apply to trailers and semi-trailers transporting hazardous products such as fuel, chemicals, etc., either in tanks or containers, which in this case have their own legislation.



Due to the position of the suspension, usually the front B-trains, road trains and dollies are exempt from the reinforced bumper. For semi-trailers exempt from the bumper, Randon must include in the vehicles' invoices the expression: "Authorized by DENATRAN according to item V, art. 2 of CONTRAN Resolution #152/03 - exempt from bumper."



Important:

Let it be clear that Randon neither produces nor delivers products that violate the current legislation.



Comment:

The owner is responsible for the inspection and maintenance of the reflective bumper sticker, in order to ensure its preservation according to the current legislation of the country.

Side Protector

According to RESOLUTION #323, of July 17 2009, it establishes the technical requirements for manufacturing and installing the side protector for cargo vehicles, Randon Implements equips its products according to the resolution, with side protectors developed with innovation and features such as: model standardization, bolted couplings, reduced weight and fast and flexible assembly and operation.



Legislation

Art. 1 Trucks, trailers and semi-trailers with PBT total gross weight over 3,500 kilograms (three thousand five hundred kilograms) new, from the factory, domestic and imported from January 1, 2011, may only be registered and licensed if they are equipped with the side protector that meets the specifications. The legislation in effect requires that at least one section has the marking, Randon records in bas-relief or glues a sticker behind the protector with the manufacturer's name and CNPJ.

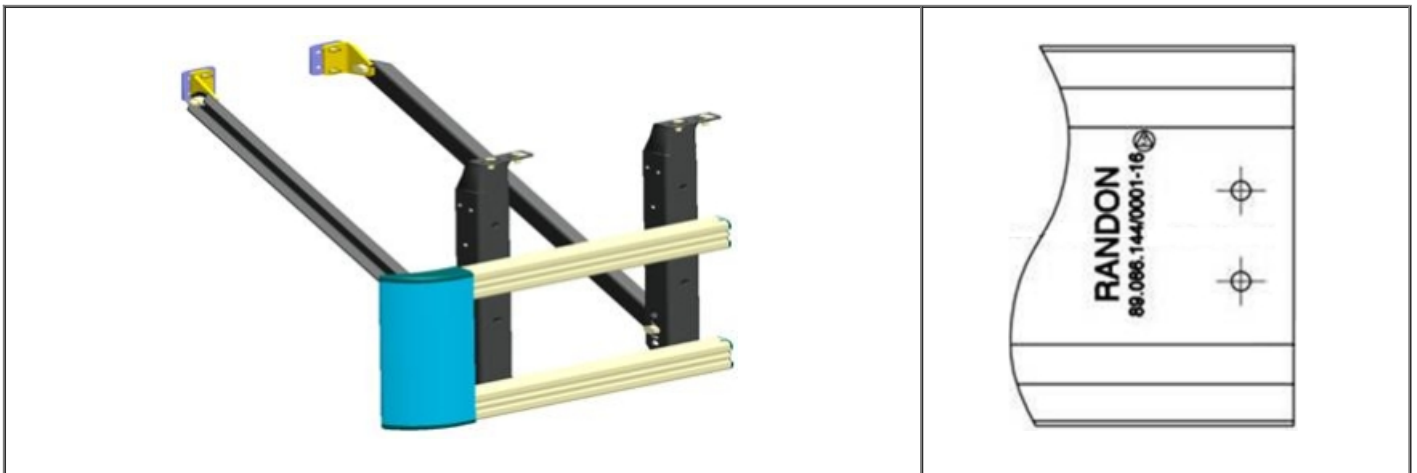

Comment:

The owner is responsible for the inspection and maintenance of the bas-relief or sticker with Randon's name and CNPJ, in order to ensure its preservation according to the current legislation of the country.

Purpose

Avoid or minimize collisions, preventing motorcycles, bicycles or small vehicles from entering under and being crushed by the wheels of the truck or train.

Side Protector Operation

To operate the side protector in tilting areas, follow these procedures:

1. Remove the lock (ind.1);
2. Move the blade upwards (ind. 2);
3. Move the blade 20 mm outwards of the implement to decouple;
4. Lower the blade;
5. Rotate the set approximately 130°, always pulling the blade;
6. Press the set to lock.

To lower, follow the inverse operation.

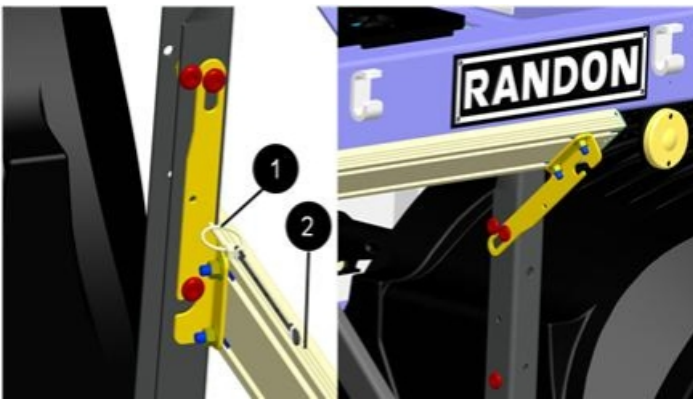

Attention:

See the maintenance and torque table to keep your product in perfect operational condition.



Comment:

To fasten the M10 screws used to fasten the aluminum blades, apply chemical lock and torque of 5 to 6 kgf.m.

Randon guides that implements equipped with guard at the back swing be at the correct inclination to avoid shocks on ramps and road unevenness.



Attention:

The maximum ramp angle is 9° or 16%.

Subida

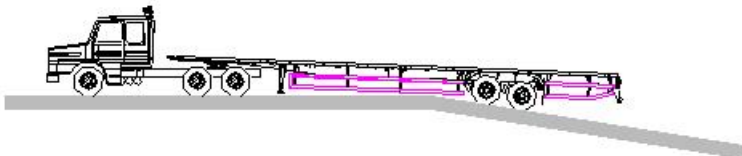
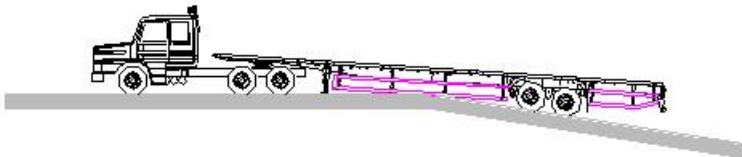
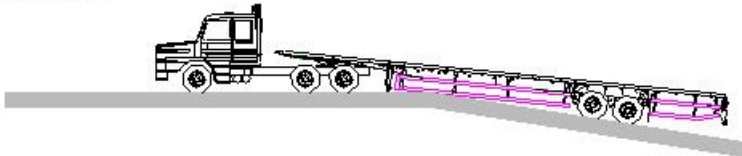

Descida



Note:

Ordinance #1283/2010 exempts some products and models from the side protector.

- **PRODUCT:** Sugarcane, carry-all, tipper (single side), and beverage bodies;
- Rear region to the rear axle (rear overhang), where the spare is installed;
- Stretching region of stretchable products;
- Sliding Chassis: 2.5 m from the tire tangent;
- Rear region to the rear axle (rear overhang) of semi-trailer, trailer body of the tipper types and tilting silo;
- Regions where the protector must have lengths equal to or less than 750 mm.

Position Lights

Randon's implements meet RESOLUTION #227, of February 9, 2007, which establishes requirements regarding lighting systems and vehicle signaling.

- Horizontal angle, 45° inward and outward;
- Vertical angle, 10° above and below the horizontal.

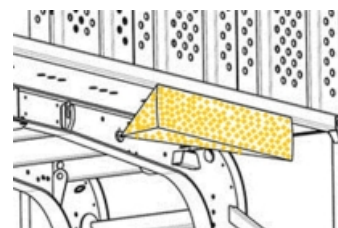

Required Equipment

Randon's implements meet all mandatory equipment according to RESOLUTION #14, September 1998, such as:

1. Rear bumper;
2. Rear wheel protectors;
3. Red rear position lights;
4. Parking and service brakes, with independent controls for vehicles with a capacity exceeding 750 kg and produced from 1997;
5. Red brake lights;
6. Rear plate lighting;
7. Amber or red rear direction indicator lights;
8. Tires that offer minimum safety conditions;
9. Bounding and side lights, when its dimensions so require.

Reflective Stickers

Randon's implements meet RESOLUTION #128, of August 6, 2001 and Ordinance #20 of March 18, 2002. The reflective devices are fastened to the side and rear of the vehicle, along the bottom edge, alternating red and white, horizontally arranged, distributed uniformly covering 33% (thirty-three percent) of the extension and the side edges 80% (eighty percent) of the extension of the rear edges.

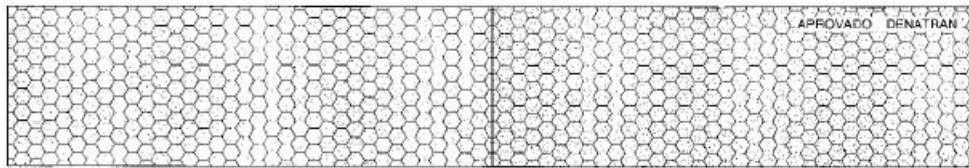

Comment:

The owner is responsible for the inspection and maintenance of the reflective stickers in order to ensure their preservation according to the current legislation of the country.

Transport of Hazardous Products

To transport hazardous products, Randon meets RESOLUTION N° 420, of February 12, 2004, having hazard signs on the implements (diamond-shaped) and the UN number (rectangular) fastened on the sides and rear. The position and dimensions of the signs meet ABNT NBR 7500.



Comment:

The owner is responsible for the inspection and maintenance of the hazard signs in order to ensure their preservation according to the current legislation of the country.

Transported Cargo

Randon's implements meet RESOLUTION #290, of August 29, 2008, on the correct cargo distribution between the tractor and semi-trailer vehicle. If the capacity (net cargo) exceeds the value reported on the sign, the product automatically loses the warranty and Randon is not responsible for fines resulting from excessive cargo or damage caused to the implement.

MISUSE OF THE EQUIPMENT



RANDON warns that misuse of the equipment, in addition to damaging it, will cause warranty loss.

RANDON considers as misuse:

- Overload;
- Transportation of loads not recommended for this type of equipment;
- Any alteration performed in the equipment without the previous authorization of RANDON;
- Improper maintenance and careless use of the equipment;
- Maintenance services performed by non-authorized third parties;
- Transportation of concentrated loads. Loading concentration has some restrictions, as this product has been designed for the transportation of evenly distributed loads. In case of doubts, please check with the factory;
- Travel in speeds that are not compatible with the road conditions.

Special Care with your RANDON equipment

- Carry out the tasks regarding use and maintenance within the safety regulations, thus avoiding damages to the equipment and possible accidents;
- Keep the equipment always clean and in good conditions, always replacing the damaged or worn parts / pieces;
- Use, at replacements, only genuine RANDON parts and components, guaranteeing the performance, functionality and durability of the equipment;
- Not transporting materials which are not within the specifications of the equipment.



Attention:

When using the tarpaulin on body, make sure it is well stretched and fastened, avoiding folding, creases or loose parts that may cause tears, deformations and others.

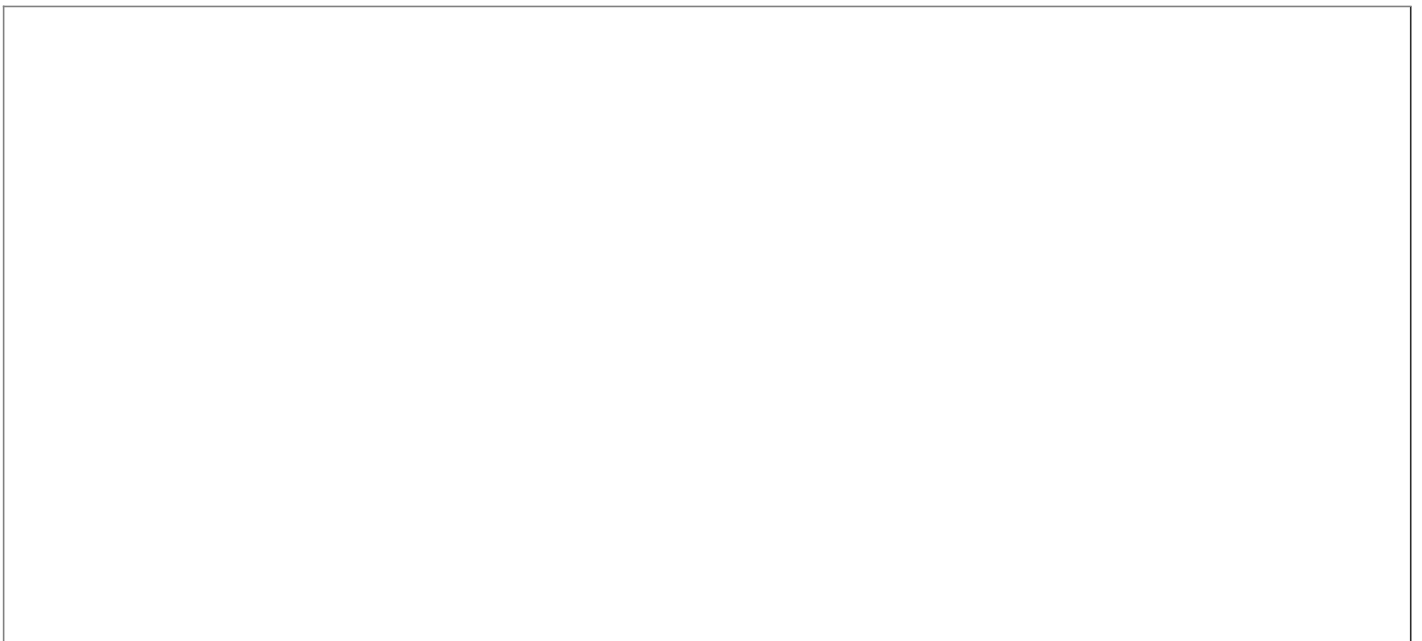

- The texts, specifications and illustrations regarding to this manual refer to the information available at the time of its publication;
- RANDON equipment are in continuous development. Therefore, the information contained in this manual may be changed without previous notice.



DELIVERY CERTIFICATE

<p>ATTENTION:</p> <p>Dear Owner / Driver</p> <p>This Certificate of Delivery and Beginning of the Warranty shall have all its fields filled in correctly. The lack of information in this document will cause the loss of warranty of the equipment.</p>		<p>CERTIFICATE OF DELIVERY AND BEGINNING OF THE WARRANTY</p>	<p style="text-align: center;">DECLARATION</p> <p>I declare to be aware of the information, guidelines and conditions of maintenance and correct use of the implement acquired, indicated in the Certificate of Guarantee and Owner's Manual, received along with the RANDON implement. I also state that I have received the technical delivery of the implement acquired having knowledge of the operation and of the consequences, being responsible for them, when not fulfilled.</p> <p style="text-align: right;">Local: _____</p> <p style="text-align: right;">Data: _____, _____, 20____</p> <p style="text-align: center;">.....</p> <p style="text-align: center;">Stamp and Signature of Delivery Officer (Factory / Distributor)</p>
	<p>Name of the customer:</p>		
	<p>Address:</p>		
	<p>NIN/ ENI:</p>		
	<p>Telephone/ e-mail:</p>		
	<p>Model / Product:</p>		
<p>No. of the Chassis:</p>			
<p>Distributor / Assembler:</p>			
		<p>Responsible for Withdrawal</p>	<p>Name:</p> <p>NIN:.....</p> <p>.....</p> <p style="text-align: center;">Signature</p>

ATTENTION

This Certificate of Delivery and Beginning of the Warranty shall have all its fields filled in correctly. The lack of information in this document will cause the loss of warranty of the equipment.

**RANDON S.A. - Implementos e
Sistemas Automotivos**

**To: Setor de Serviços (service
department)**

**Av. Abramo Randon, 770 - Caixa
Postal 175**